

Treadle Hammer

Lubricate all moving joints weekly or daily under hard use.

Inspect welds for cracks and retighten all bolts and nuts after the first month and on a regular basis.

If you hear a rattling noise, first check the wedge. When it loosens up, you can hear it. If the wedge is tight and it still rattles, then check for loose bolts and nuts or broken welds or parts.

If your hammer behaves strangely, be careful where you put your hands or other body parts as you check to find the problem. The crooked first joint of my left ring finger continually reminds me not to ever place it on the anvil again.

Respect the power of this hammer.

Have a good hold on the crank before you loosen the slider clamps. The slider will move up (usually) when it gets loose.

Always have a tool or a hard plate in both the hammer and anvil unless you are punching through a hole over the hardy hole. If you strike tools without a hard plate in the hammer and anvil, the edges of the holes will be rounded and upset. You will not be able to get tools in or out of the holes.

Whenever possible, work with your stock or tool on the center of the anvil. When you work on the side or edge of the anvil, it puts a twisting force on the hammer and linkage. You can't do everything in the middle but when you can, use the center part of the anvil. When you are using a struck tool near the edge, the hammer can miss the head of the tool completely or partially. If the hammer hits the edge of the tool head, it can cause the tool to kick out or twist.

Keep the tools vertical. If they are tilted much

they will be twisted to one side or fall over. This can break tools, fingers and damage your work.

Never put your fingers through holes in wire handled tools. If the tool kicks out or twists, your fingers can be broken. Fingers can be pinched between tool and stock if the tool tilts. These precautions apply to use of handled tool under power hammers and the same precautions used with power hammers should be used with the treadle hammer.

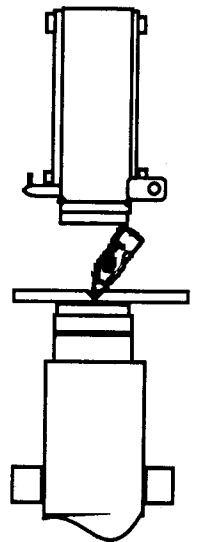

Center Punching

One of the first things to be done when starting some projects is to mark points for fullering, punching holes, cutting or other operations. This is easily done on the TH with a handled center punch. Make a mark deep enough to see under scale on hot iron.

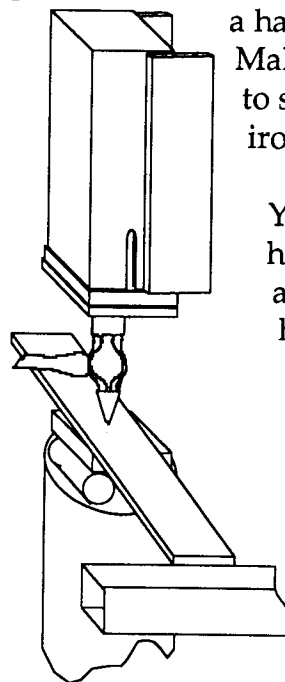

You will notice that a hand is never used to hold a tool directly under the hammer. If you wish to use a tool that does not have a handle, then grip the tool with vise-grips, tongs or pliers. Then make a tool with a handle or weld a handle to the tool.

Cold Cutting-Countersinking and Dimpling-Bending

Cold Cutting

Thin soft stock may be cut cold or cut part way through and bent to break off. This works better with 1/8" to 1/4" stock.

Put a 1/8" or thicker piece of aluminum under the stock before cutting through to save the tool edges and keep from marking the anvil hard plate. The cold cutter should have a blunt taper, nearly 90°.

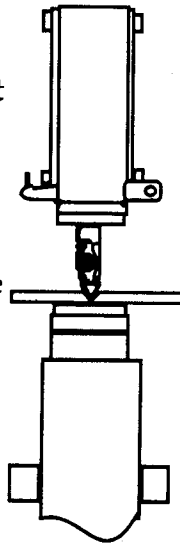

Countersinking and Dimpling

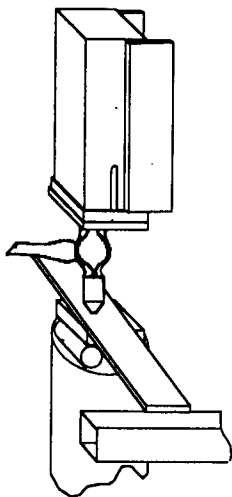

If your project is to be fastened to a wall with screws, then make a countersink for the screw head. After the stock has cooled, drill a hole for the screws. For screws 3/8" or larger, the hole may be punched.

A more interesting look is provided by making a dimple depression for the screw head. A small ball peen (or a ball peen forged to smaller diameter) is one way. Another is to weld a ball bearing to a paddle shaped handle.

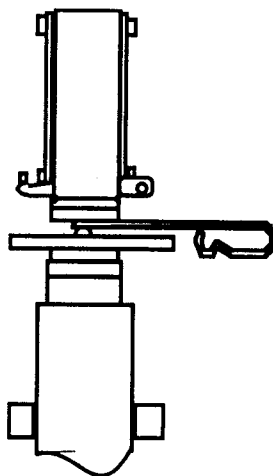

©Clay Spencer1993

Bending

Controlled bending (or straightening) is done with stock over two supports. The simplest is two pieces of 1" round stock welded to a base. Some are spaced 2" apart and others are four or more inches apart.

A V-block is used for right angle bends of flat stock. Again, thin stock can usually be bent cold. Some of the V-blocks and bending bolsters have hardy tangs while others just rest on the anvil hard plate.

The radius inside the bend determines what top tool you will want to use. For the sharp 90° bends, use a 90° top tool such as a cold cut. Where you don't want to mark the stock or where you want a large radius, you should use a large diameter fuller.

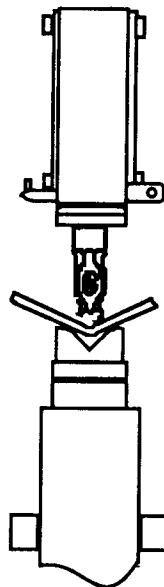

Where marks outside the bend would be objectionable, a super large V-block with rounded edges can be fabricated of 1/2" x 2".

The hard plates may be used as large flatters or hand held flatters may be used. The hard plates are useful for straightening stock, also. Rotate the stock between blows.

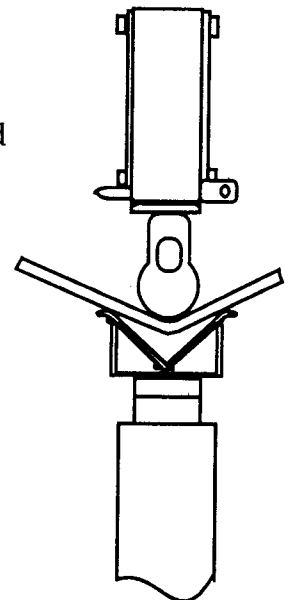

Fullering and Drawing

Fullering

Spring fullers or the less common hinged fullers are easily used under the treadle hammer. The spring fuller can twist or not be held vertically one above the other—this results in the grooves not being exactly aligned. Be careful of this.

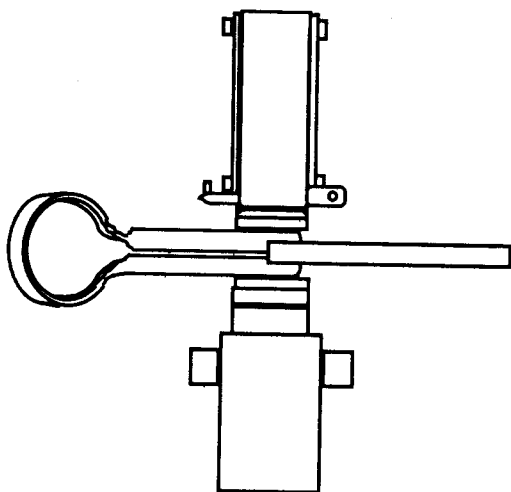

The spring fuller is great when you are doing operations with several different tools in one heat. Sometimes if the spring closes it may be difficult to get the work between the fullers. Put the stock in the spring loop and pull out to the working area or put the thin dimension of the work between the fullers and twist to open.

Unless I need to change tools during a single heat, I prefer to use the top and bottom fullers mounted in the TH hammer and anvil. They can be lined up exactly. You can see the result of each hammer blow since the tool is raised clear of the work each stroke. The work can be placed at the

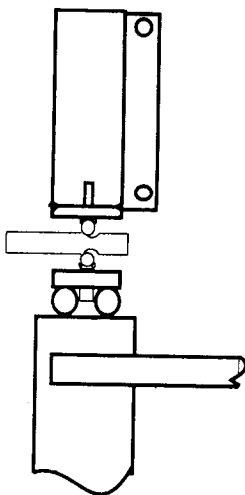

exact spot desired and can be moved 1/16" for the next blow. You can use top and bottom fullers of different diameters or a top (or bottom) fuller alone.

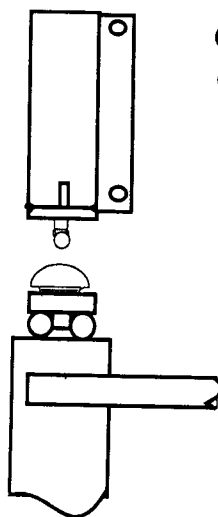

One special combination is a 1" diameter top fuller with a 4" diameter mushroom or ball on the bottom. This is especially good for drawing out shapes like arrowheads, spatulas, or some leaves where you draw a part out extreme shapes.

Fullers also may be square or triangular or have other special shapes.

Tools may be mounted crossways in the TH for making fullers in the middle of long stock. One of a pair of matched fullers should have the U at 90° to the fuller while the other U should be parallel to the fuller. This way the pair may be used in line with the hammer or at 90° to the hammer.

A pair of hinge finials may be forged in the center of a bar by making 3 fullers. Center punch on the edges to mark the fuller location. Turn the bar over every few blows to help keep everything equal. Draw out the tapers from the outside fullers. Cut the stock in two by fullering the center until it pinches the bar in two parts. Be sure the stock is long enough to turn both eyes.

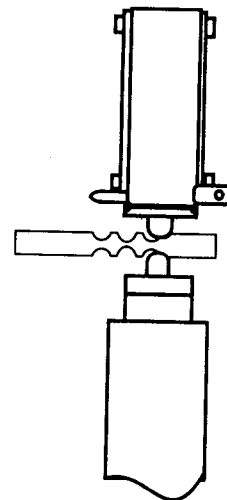

Fullering and Drawing, cont'd

Drawing

Fullering tools in anvil and hammer can be used to draw stock. This is an energy intensive sport. Use the power hammer. Fullers of 1" diameter or larger in top and bottom are best for drawing. Make a series of fullering blows and then smooth out by fullering the bumps. Lots of square inches are usually being worked when fullering with large fullers, so keep the stock hot.

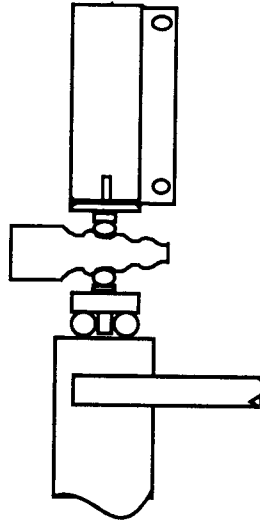

Grooving a flared fishtail with a hand held fuller is quickly done. Mark the desired grooves on the flare and fuller the grooves by walking a hand held fuller. The fuller may be narrow or wider, depending on the effect desired.

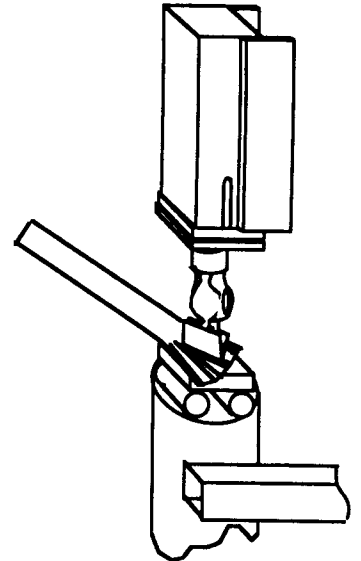

There are many other tools used for fullering, drawing and flattening the stock after the fullering or drawing.

Get a smooth finish by using a flatter on flat or tapered stock. The hammer and anvil hard plates may be used as flatter on straight sections.

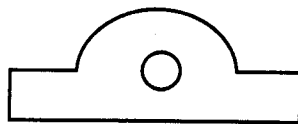
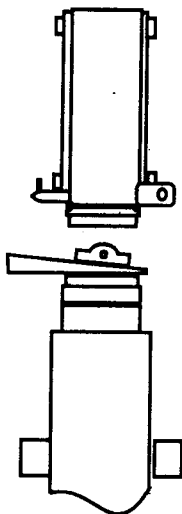

See **THE BIG HAMMER, Bituminous Bits**, Volume 5, No. 6 or the Reprint of that issue for many tools that can be used with the treadle hammer. If you don't have one, you can get a copy from ~~Norm Larson~~ or from ~~Clay~~ *AFL website alaforge.org*. Some of the fuller shapes shown are half round, round, V, U, ball, tapered, and double ball.

CHECK ALAFORGE.ORG FOR CLAY SPENCER TOOLS (small)

Anvil fullers may be used for drawing stock with the flat face in the hammer. You can also use a handled top fuller with the bottom fuller or with the flat face in the anvil.

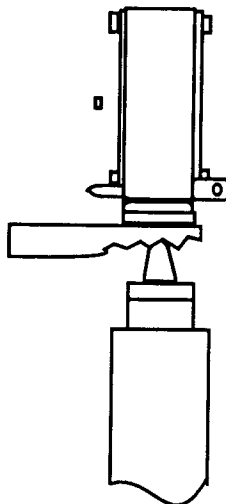

Swaging

Swaging

Spring swages are used for necking down pipe for candle cups or necking round stock. Same comments apply as above for the mounted fullers.

A hinged swage may be changed almost as quickly as a spring tool and is more precise. Swaging deep grooves can result in the swages being pinched by the work unless the swage sides are tapered.

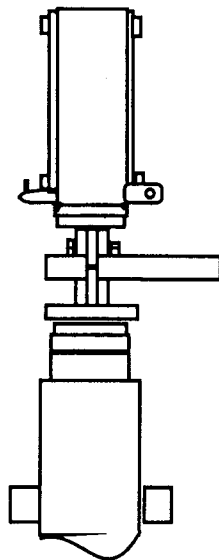
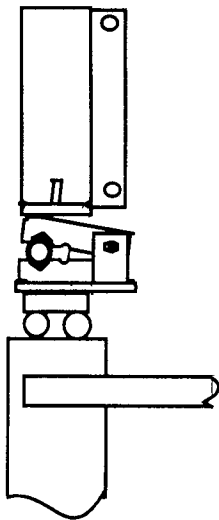
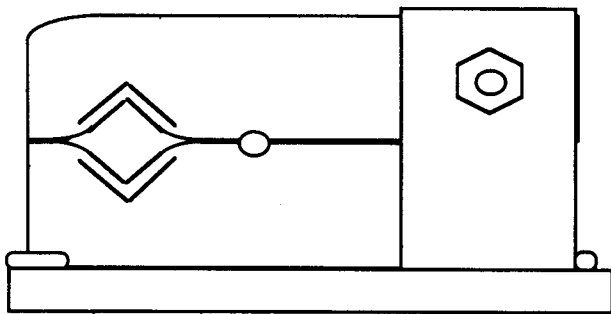

Individual top and bottom swages may be mounted in the hammer and anvil for other jobs.

The regular anvil bottom swage and handled top swage may be used with the treadle hammer. Draw the stock to just a little larger than finish size on a power hammer or TH with drawing or flat dies. You will usually be working with large areas on cold tools so keep your iron hot and rotate after each blow.

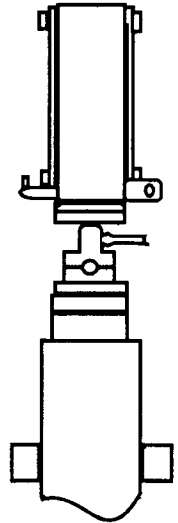

Swages for special shapes may be made from straightened sections of ball bearing races. Roger Lorraine told me about this idea. The ones with grease seals on each side make nice designs in the edges of flat stock or on round

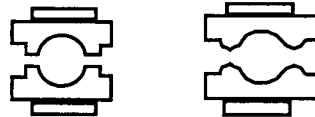

or square stock.

You will need a starter section because the stock is lengthened when swaged. Grind away both edges from the high point of the race to give clearance. This starter section should be at least one inch long. Have a couple of inches of the original race just behind

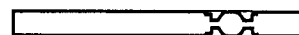
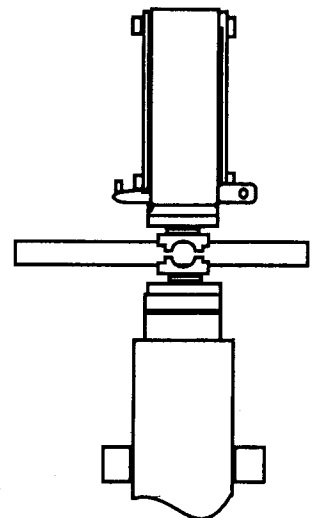

this. Forge nearly to finished depth on all desired surfaces in the starter section and then move to the finishing section.

Tenons

Tenons

Tenons can be forged with traditional tools or with special jigs. Determine the length of original size stock needed to make a tenon of the required length. Figure the cubic inches of steel in the tenon and convert to the required length of original stock. Generally the tenon will be more than four or five times as long as the original stock.

Mark all around the stock with a light mark, cold. Heat and hammer down on a butcher on the mark, flat sides and corners. Don't cut too deep or a cold shut is inevitable. Keep the cuts centered on the stock so the tenon will be centered. Keep the stock horizontal or it will be bent with each hammer blow.

Draw the stock to slightly larger diameter than the tenon diameter using a set hammer on a sharp edge of the anvil. A square stake may be used for the sharp edge of the anvil.

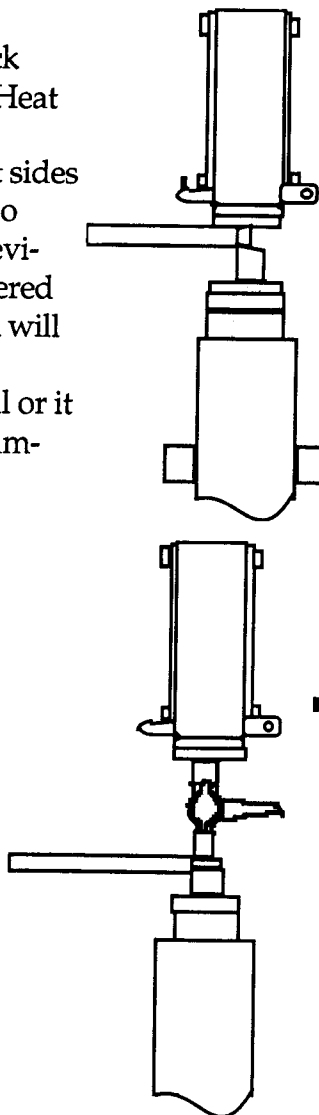

Round up the tenon with a swage of the correct diameter.

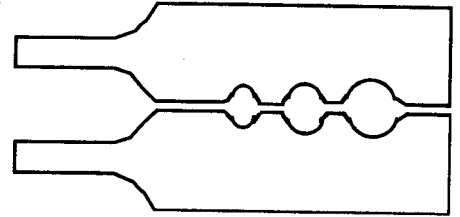

Rotate stock between hammer blows. Keep the shoulder of the tenon against the swage. Reheat as necessary. This is heavy duty work and is better done with a power hammer.

Use a monkey tool to square up the stock around the tenon. If the length of the baluster is too long, the monkey tool is used to shorten it by upsetting.

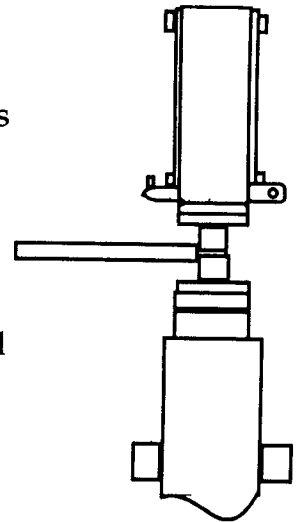

A swage may be made with a starter section and a finish size hole. This swage should be made from tool steel. Clamp a business card between the two swage halves and drill two holes (finished tenon size). Drill a larger size (about 1/8" larger) hole from the back on the starter side but don't drill through. Leave about 1/16" not drilled with the larger drill. Grind the sides of the drilled holes away on both holes. Grind about twice as much as you think is required.

Start the tenon as before. After going around with the butcher, reheat and use the starter section to round up the butchered area. Rotate the stock each hammer blow and keep stock horizontal. Be careful to keep the cuts even so the tenon will be centered on the stock. Finish as above with set hammer/stake and swage.

Bituminous Bits/Alabama Forge Council

Cutting

Cutting

Standard hot cuts may also be used for cutting off stock but a soft plate should be used under the stock to prevent damage to the cutter edge. Soft iron will work but aluminum protects the edge better.

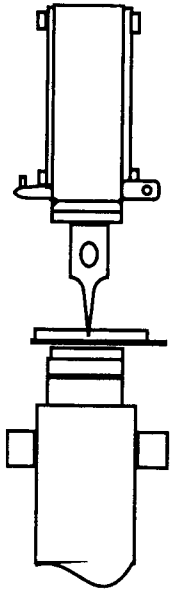

The older blacksmith hot cuts and punches are normally about 8" high and comparatively heavy. This means the hammer hits the tool at a higher level - you have to adjust the hammer head higher or lose a little energy. Most of the cutters and punches I use are 3 or 4" high.

The hammer height doesn't need adjusting and they are lighter weight and don't have as much mass to get moving.

Better tools for cutting are the ones made by Robb Gunter from Atha Pneu S-1 tool steel. It is available from Crucible Materials Corporation. Flutagon or Atlantic 33 is also good for hot cutting. If you are going to drill a hole for the handle, be sure to drill the Atha Pneu

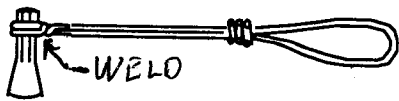

before forging if you can. Even after annealing, it is much more difficult to drill after it has been forged.

Handles may be made of a ²²24" length of ~~1 1/4~~ or 5/16" round stock and wrapped around a 3" high cutter. Many types of tool steel do not weld readily to the handles. Try MIG welding or preheat and postheat the stock to at least 400° F before stick welding. ~~The Atha Pneu S-1 tool steel can't be welded by arc~~

welding but MIG welding seems to work.

~~Another handle attachment is to drill a 3/8" hole through a 1" length of 3/4" pipe and weld a 5/16" nut over the hole. Use a short machine screw (or set screw) to hold the tool~~

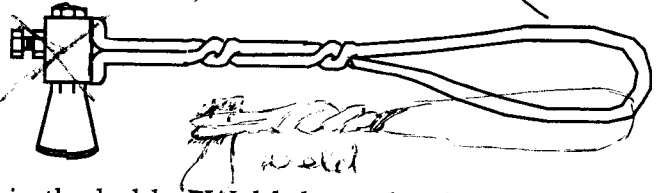

in the holder. Weld the ends of a folded 22" length of 5/16" handle to the pipe. Heat the rod and twist.

The cutter may be held with special tongs or with vise grips. Do not hold any tools by hand with your hand under the hammer. The tongs, vise grips or pipe holder allow the angle of the blade to be adjusted in relationship to the handle.

Cool the cutter in water frequently. Wipe excess water from the tool to keep from cooling the stock. The Atha Pneu or Flutagon cut well while hot and don't require cooling. Cutting off stock on the treadle hammer is easier and more precise than on a hardy.

Ball peen hammers, made from good steel, may be used to make cutters, punches, center punches, fullers, rivet sets, set hammers, eye punches and a whole bunch of other tools. Be sure to anneal or normalize the part to be struck, usually the flat head. Don't heat the steel too hot or forge it below orange. If heated too hot, the head will come apart the first time you hit it to forge it. After forging, be sure to **normalize or anneal before quenching and tempering.**

Cutting, cont'd

Cutting off stock on the treadle hammer is easier and more precise than on a hardy. You can cut stock up to 2" thick with a hack and snapper similar to the ones used with power hammers. It is safer to use these tools with the TH than a power hammer, especially on drawing dies.

The hack should be nearly as tall as the stock or taller. Cut through from one side until about 3/8" or 1/4" is left.

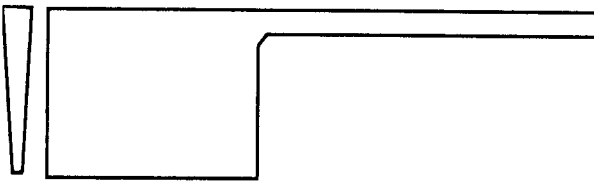

Turn the stock over, place the snapper above

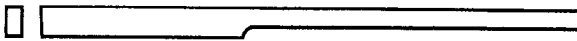

the uncut section and snap it into with heavy blows. You should knock out a small piece of

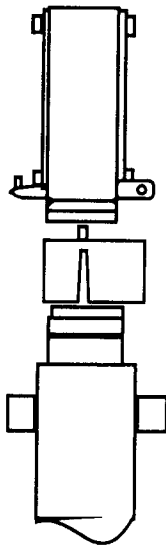
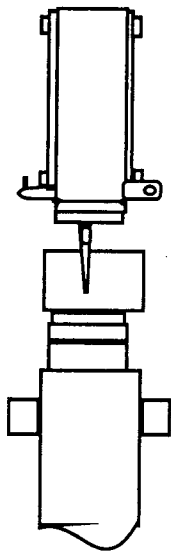

stock without any ragged edges left.

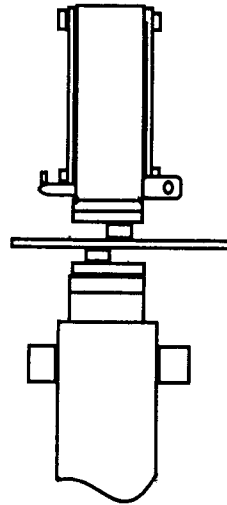

Thinner stock may be sheared with one hammer blow with spring shears. (The long spring handles of these shears, or most other spring handled tools, are not shown.) Don't get your fingers between the handles. The shear blades should overlap just slightly, with more overlap required for thicker stock.

A scissors cutter as used by Clifton Ralph under the big hammer works on a foot hammer (as Clifton calls the treadle hammer) also.

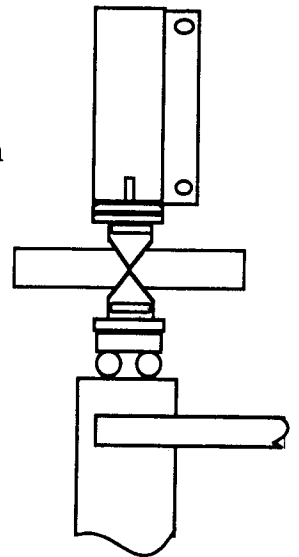

The cutters are triangular in cross section. There is a square or rectangular section at either end of the triangular section. These serve as stop blocks to keep the cutters from touching each other.

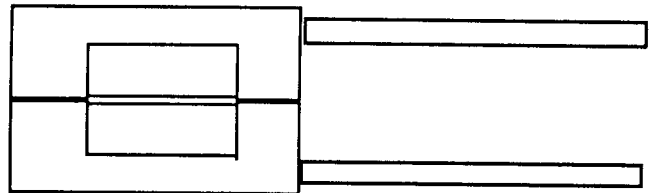

For the TH, top and bottom cutters without the spring handle would work. I sometimes use top and bottom fullers for cutting off stock. The smaller diameter fullers require slightly less energy.

Splitting

Splitting flat stock is quickly done under the TH. Split the end first and continue splitting up to your center punch mark. Do all your splitting from one side. Finish your split with a side cut chisel in the vise or with a hot cut lengthwise in the vise.

For cutting a long split, the flat end of the cutter should be round, about a 3" radius seems about right. Don't lift the cutter out of the crease but rock back and slide forward along the groove and rock forward up on to an uncut section, keeping part of the cutter always in the groove.

When splitting thicker stock, such as 1" square, to make a split basket or Freidrich cross, it is better split from both sides (or all four sides). Center punch both ends of the splits on all sides. Cut down 1/4" on one side

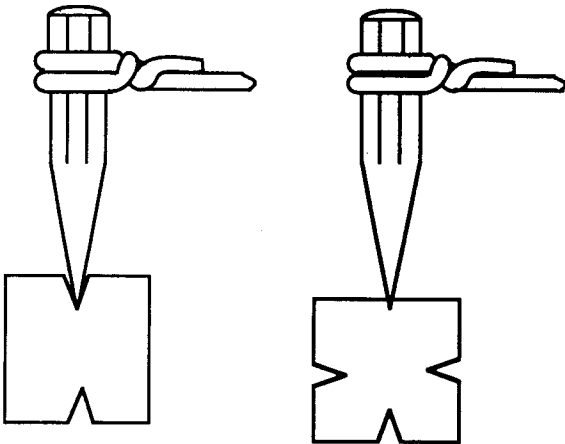

for the full length and turn over to the opposite side. Keep all cuts centered and keep the cutter vertical.

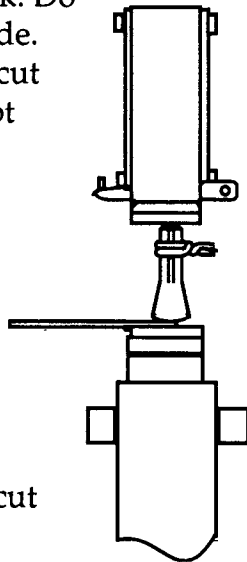

Then cut the remaining sides. Continue cutting to an even depth all around until cuts meet in the center. Cut out any large rags where cuts did not meet in center. Use side chisel with stock in vise to open cuts to the end.

Special cutting such as cutting dragon ears or wizard whiskers off the corner of the stock is started by marking the cut about 1/8" deep one face. Put the stock in a V-block and continue the cutting on a 45° angle. A large headed cutter may be necessary to keep the tool from kicking out unless you can hold the cutter vertical.

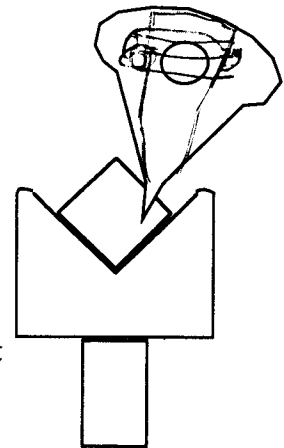

The tool will be kicked out to one side unless a vertical line can be drawn through the point and the head of the tool. A large round or wide head will allow you to tilt the tool to cut at a larger angle. Don't try to cut all the way through in the V block. After you have cut down until there is about 1/8" left uncut along the length of the cut, put the stock in the vise and finish the cut by cutting from the end. This seems much quicker for me and it doesn't upset the cut ear or whisker so much.

Soft, thin stock, 1/8" or less, may be cut with a cold cut. Nick on one or more sides and break.

Cutters may be straight or curved to various radii. The cutting edge may be straight on the outside or on the inside of the curve, depending on whether you wish the inside or outside of the cut material to be vertical.

Slitting / Punching

Slitting holes

To put a 1/2" square hole through a length of 1/2" square stock requires slitting a hole and upsetting it to near round shape.

The chisel is narrow and straight.

The cutting edge is rounded and the sides are sharp. The width is proportional to the diameter of the hole. According to Francis Whitaker's book, **The Blacksmith's Cookbook**, the chisel width should be the hole diameter + 40%.

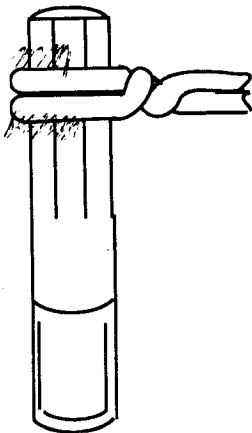

Slit part way from one side and then finish from the other side. Be sure slits are centered from side to side and ends line up with each other.

Open the hole part way and then upset the stock around the hole with localized heat by hammering the end of the stock.

Drift the hole round. If you want a square hole, drift it round before drifting it square. One of the more difficult parts is to align the square drift so the resulting hole is square with the stock. Look down on the drift from directly above.

Punching

The treadle hammer makes punching holes much easier than one man can do by hand. Punch most of the way through from one side and then turn over. Center the punch over the dark spot and punch the slug out.

For a deep hole, you must cool the punch in water. Dip the wet punch in coal dust to save

having to put the dust in by hand. Sometimes a bolster with round holes is useful for knocking the slug out.

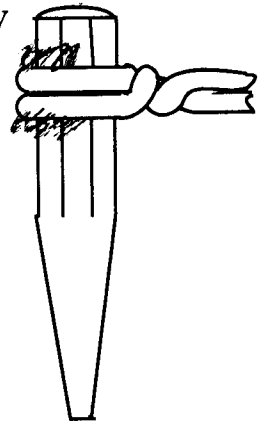

Rotate and/or tilt the punch on each hammer blow to help keep it from sticking. Be sure not to hammer too hard on a hot punch when it is in the hole. It can mushroom in

the hole and get stuck. Sometimes hammering on the side of the stock with a stuck punch in the hole will loosen it. Turn the stock on edge and hammer between the TH hard plates. Grind any mushroom ends off your punches before use.

Punched holes may be enlarged by driving a tapered punch (or drift) into the hole from both sides over the hardy hole or bolster with the right size hole. The old blacksmith punches generally have a 3" tapered section which is useful for enlarging holes. Flatten ridge around the hole between the hard plates and then drive the drift in lightly from both sides..

Punches are usually round but may be other shapes such as square, diamond, octagon, or heart shaped.

Slots are punched with long narrow punches. A bolster with a narrow slot is useful. Bend a length of 3/4" square stock so that you have a 1/4" slot about 3" long.

TH Tools

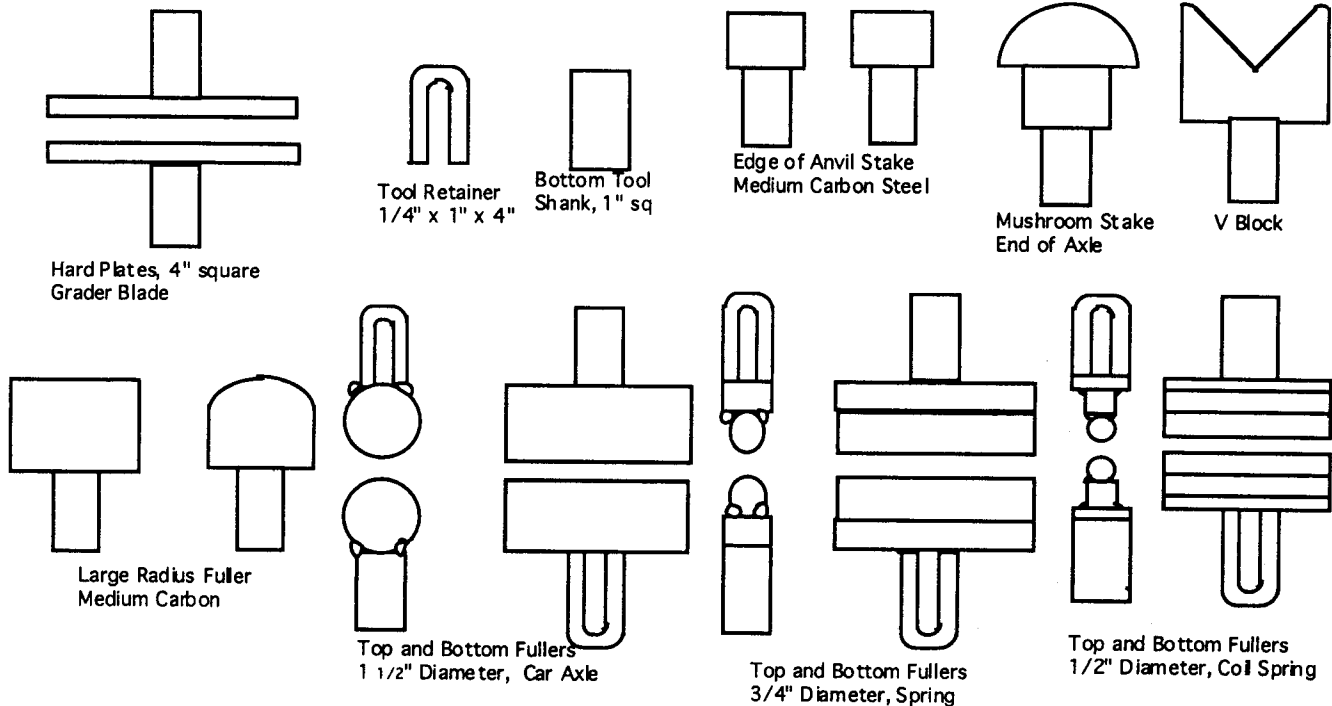

These are some of the tools I use most in the hammer and the anvil of the TH. The tool retainer must be welded on top of the top tools. Many types of tool steel do not weld readily. 7018 rods are best used when welding medium or high carbon or other tool steel. Many times you can make a successful weld by preheating (and post heating) the stock to at least 400° F before stick welding. Sometimes MIG welding is OK if you get enough penetration-requires a bigger MIG than the 110V jobs.

It is best to weld a U tool retainer on both top and bottom of matched sets of tools. Weld one at 90° to the tool and the other in line with the tool. That way the set may be used sideways or lengthwise to the hammer. Usually a four inch length is long enough for most hammers. These tools are heated to red and fitted in the hammer. Take one or two good blows to seat

the tool. Reheat and normalize.

The heads of the struck tools are normalized and the cutting/fullering ends are quenched and tempered to blue.

The ball peen tools and other handled tools may have wood or wire handles. Since you will not be hammering with these tools, handles do not have to be fitted as well as handles used for hammering. But you don't want the head to be loose and fall off the handle.

A folded length of 3/8" round stock stuck through the eye and welded on the off side makes a good handle that does not have to be removed for reforging or heat treating. Ball peen hammers, made from good steel, may be used to make cutters, punches, center punches, fullers, rivet sets, set hammers, eye punches and a whole bunch of other tools.

Blacksmith's Typewriter

Name plates, signs, or belt buckles may be carved or decorated with chisels under the TH.

Decorative borders are easy. You can use a straight line or dashed line about 1/4" or 3/8" in from the edge to start a border. Add circles, diamonds, lazy S's for a rope pattern, X's,

they don't touch the other line.

Curved sections will require cutters of a radius near to the desired shape. You can cheat a little by tilting the cutter. A short, curved chisel with ends rounded up will be helpful to smooth out the curves and connections.



dots or what ever comes to your mind to decorate the space between the edge and the line. The edge of the stock should not be left in the cut or raw state. Taper the edge or upset it or lightly hammer it.

For a name plate, draw the design on the metal with silver pencil. Don't forget the legs, border area and space around the letters. For letters, I sometimes use the computer to print the name and expand it to the desired size. Tape the paper in place over a clean piece of 1/8" or 3/16" stock. Cut through the lettering on the paper with straight and curved cutters, but don't go deep. Pay careful attention to the alignment of the tops and bottoms of the letters.

Leave a 1/4" strip on each end for the legs. Remove the paper and recut the letters to depth. Where parts of letters intersect or cross will require extra attention. Sometimes, the intersecting lines are left a little short so that

For name plates, I usually carve a small flower at each end of the name. Use small eye punches, center punches, and curved chisels to make the flowers or other design.

When the design is complete cut the 1/4" legs from each end. Cut these down the side with a hot cut or saw. Heat at the corner and bend the legs back about 75°. Forge the corner smooth and the leg straight.

Stamping decorative wax catchers

They can be similar to men - above. A custom-stamp, eight evenly around the catcher.

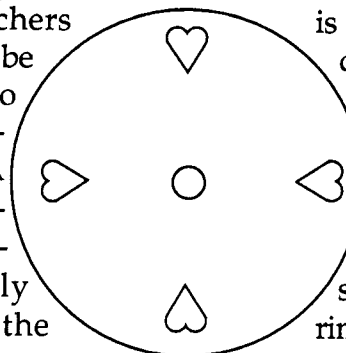

is another use. decorated borders mentioned favorite of ers is heart ther four or spaced rim of the wax

©Clay Spencer1993