

BUFFALO FORGE COMPANY

FORGES · BLOWERS
METAL WORKING
MACHINES · WOOD-
WORKERS · DRILLS



Catalog No. 801

General Catalog
of
"Buffalo"

FORGES, HAND BLOWERS, TUYERE IRONS,
ELECTRIC FORGE BLOWERS AND FORGES, POST
DRILLS, HAND AND POWER DRILLING MACH-
INES, POWER BLOWERS AND EXHAUST FANS,
HAND AND POWER PUNCHES AND SHEARS,
BAR CUTTERS, BENDING MACHINES, UNIVERS-
AL WOOD-WORKERS, STATIONARY FORGE
SHOP EQUIPMENT, DISC VENTILATING FANS,
HEATING, VENTILATING, DRYING AND
MECHANICAL DRAFT APPARATUS

Buffalo Forge Company

BUFFALO, NEW YORK, U. S. A.

In Canada—Canadian Blower & Forge Co., Ltd., Kitchener, Ont.

Foreword

In this catalog you will find a complete showing and listing of the tools which, in more than fifty years in the hands of users, have demonstrated their value.

Just as the Buffalo Forge Company was the first manufacturer to produce a portable forge with hand blower attached, so have we pioneered many other features, among which may be mentioned the all-steel, one-piece hearths on many of our forges, the improved type agricultural forge, the moderately-priced, accurate 12-inch Hi-speed Drill, the volume fan and the all-steel Breezo ventilating fan.

Instructions for Ordering

Wishing to save time for our customers, and to avoid unnecessary correspondence and possible misunderstandings, we print the following:

ORDERS:

Please be careful when ordering to observe the following points, which are covered in detail in the appropriate sections of the catalog. Insufficient information holds up many shipments which might be made from stock.

Forges are shown and listed with and without hoods, etc., under different numbers. Select the number corresponding to the arrangement wanted.

State definitely if forge is wanted with or without water tank.

Give complete information about the current for all electric forges, blowers and drills. Wall drills are furnished with chucks to take a $\frac{1}{2}$ in. straight shank unless otherwise specified.

For power blowers and exhausters clock-wise bottom horizontal discharge is standard. Note instructions for determining other arrangements.

TERMS AND DELIVERY:

Our terms are net thirty days or 1 per cent. for cash in 10 days. Those not known to us, and who have not established credit rating with the mercantile agencies, should send cash with order, or give references.

All prices are f. o. b. Buffalo, N. Y.; boxing for export is charged extra at cost. We do not send goods C. O. D. except when so directed, and with a remittance sufficient to cover carriage and C. O. D. charges both ways. On goods sent by mail, parcel post, or prepaid express, such charges are added to our invoice at cost.

BUFFALO FORGE COMPANY

Buffalo Portable Forges

Important Information

THE modern, advanced line of "Buffalo" Forges illustrated in this catalog is the result of over fifty successful years of designing and manufacturing "America's Best, The World's Standard."

Buffalo forges were the first to feature many improvements which have since become common, such as the ball bearing blower, down-draft hood, one-piece steel hearth, etc., all of which have been of benefit to the user.

In this new catalog another exclusive Buffalo feature is presented for the first time.

This is the new large, pressed-steel, scroll-shaped fan-case now being used on all "Buffalo" forges. The fan-case, of heavy pressed steel construction, rigidly bolted together, provides freedom from breakage, a greater blast and is of light weight. It is the same fan housing as used for several years on the Buffalo No. 2-E Electric Blower.

The advantage of correct proportioning of a fan scroll in large fans has long been known but has never before been applied to hand blowers. The stream line effect explains the large capacity and high efficiency of the fan. A specially designed pressed steel wheel, 9 inches in diameter furnishes the blast for all blowers. The use of this standard fan case means low cost production, reduced stock for the dealer and a better product for the user.

In addition to this important improvement we have further simplified the line by the omission of the less popular numbers.

The Nos. 200, 500 and 700 hand blowers are now available on seven different hearths, making a total of 21 forges from which to make your choice, as well as electric, compressed air and oil-burning forges.

We believe this catalog shows the finest forges ever made, and feel confident that users will share our enthusiasm.

Description of Blowers Available

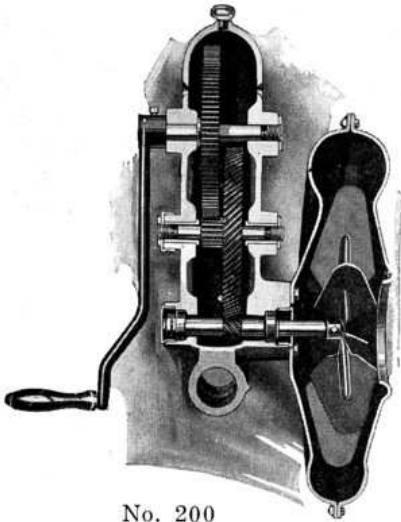

No. 200

The No. 200 Silent Geared Blower

For many years a popular and efficient outfit, this blower has been further improved by the use of the new fan case. One-piece cast-iron gear-case with removable cover keeps gears in permanent alignment and makes inspection easy. The helical pinion is cut from the steel fan shaft, and not only guarantees quiet operation, but also adds strength to the entire gear assembly. "New Departure" ball bearings are used, the best obtainable for light service at high speeds. Gear ratio is $47\frac{1}{2}$ to 1.

An eccentric main bearing permits wear to be taken up by easy adjustment on the shaft end. End thrust on shaft is taken up by adjustable ball bearing.

GUARANTEED FOR TEN YEARS

We guarantee to replace free of charge F.O.B. Buffalo, any part of the No. 200 Blower wearing out within ten years. Run the blower 24 hours per day and the guarantee still holds. The No. 200 blower is available on all forges, as shown in pages following.

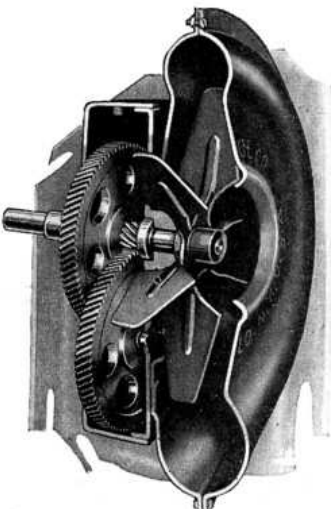

No. 500

The No. 500 Handy Geared Blower

There is little difference in the general construction of the No. 200 and 500 blowers except that the gears in the No. 500 are enclosed in an all-steel housing instead of cast-iron. Our highly developed press equipment enables us to produce stampings with the accuracy of machined castings. Radial ball bearings provide easy operation and adjustment for wear. Cut steel gears are quiet in operation. Ratio $47\frac{1}{2}$ to 1.

The steel fan case is riveted to gear case on the No. 500 blower making a rigid unbreakable unit.

The No. 700 Climax Geared Blower

For those who do not use a forge blower every day, the Buffalo No. 700 offers the greatest value on the market in a high-power, light, unbreakable and inexpensive blower head. Construction is just like the No. 500, except that bronze bushings are used instead of ball bearings. Construction and material first class throughout. Gear ratio $47\frac{1}{2}$ to 1.

The Buffalo Electric Blower No. 2-E

The series number 800 is applied to all Buffalo electric forges equipped with Nos. 2-E or 2-EH electric blowers. All six hearths listed in this catalog can be supplied with this electric blower.

Complete description of blower only given on page 15.

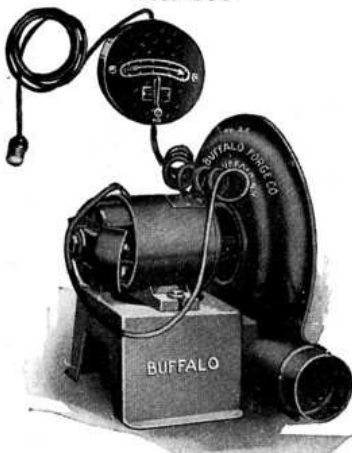

No. 2-E Electric

Buffalo

Designation of Hoods



All Buffalo forges may be had with either of two types of hoods. The majority of forges are shipped with the type shown on the two forges at the top of this page, called "windshields". This is the hood which we regularly furnish when the order does not specify.

Those who want the hood shown on the two forges at center right and bottom left, called "half-hood", can obtain same by adding the letter H to the number of the forge. Thus: No. 210-H, forge with half-hood.

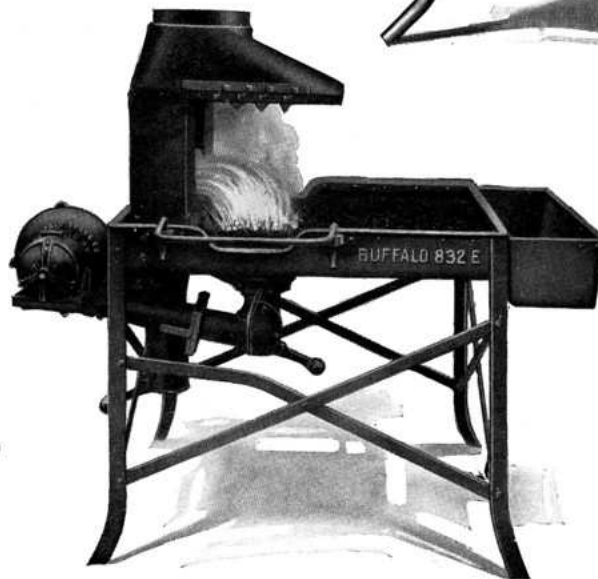
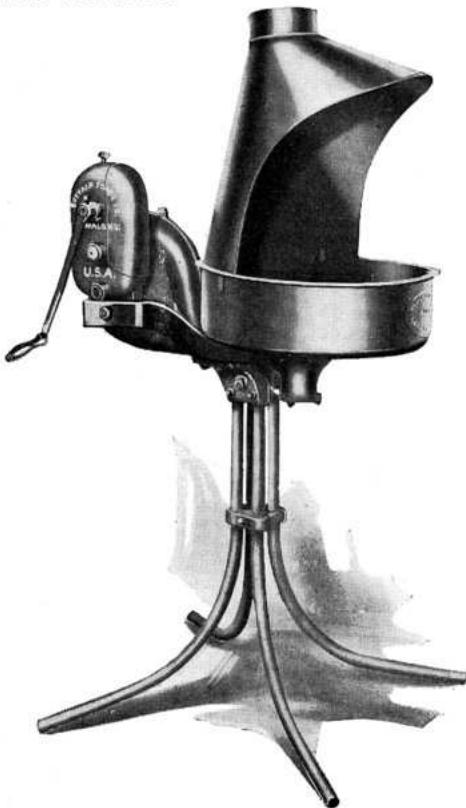
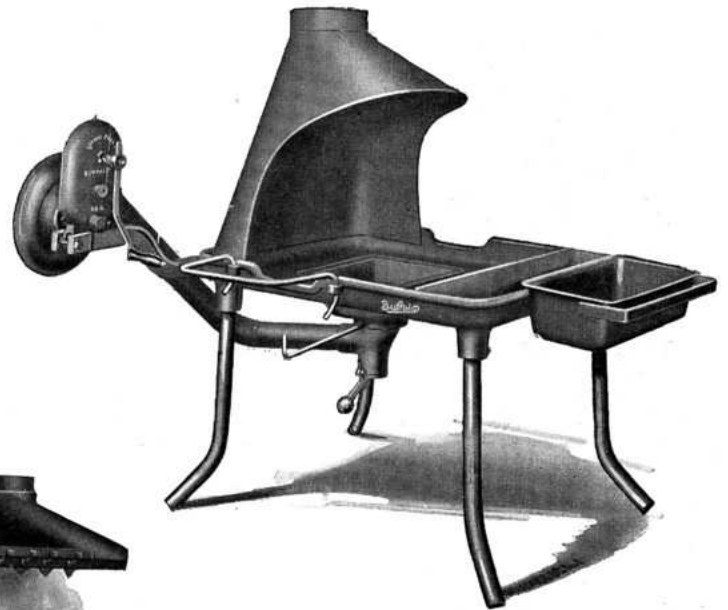

When desired, the down-draft hood shown at left can be furnished. This hood is particularly effective in removing smoke and fumes.

Buffalo

Buffalo Series 10 Rivet Forges

ONE-PIECE SEAMLESS STEEL HEARTH



Buffalo No. 210 Rivet Forge

The one-piece unbreakable, all steel hearth used on all No. 10 Forges was originated and perfected by Buffalo for the benefit of the user. Pressed out of heavy steel plate by enormous presses, the No. 10 hearth is far stronger than the old style two or three piece hearths, lighter in weight, and about 100% better looking.

Forges of this type are generally used out-of-doors or under temporary shelters, and it formerly took only a short time for moisture to accumulate along the seams, after which rust speedily destroyed the hearth. With the one-piece Buffalo hearth this is impossible because there are no seams in the entire bowl. This feature alone doubles the life of the hearth.

The No. 10 forges are supported by four heavy pipe legs widely spread at the bottom and securely fastened at top and center.

Blowers are mounted so that they can be taken off in a minute or two, in fact, the whole forge can be readily knocked down for transportation.

Four different types of blowers are available with the No. 10 hearth, as listed below.

Forge No.	Blower No.	Gear Ratio	Diam. of Fan Case	Hearth	Net Wgt.	Crated Wgt.
210	200	47½x1	12 in.	18" Dia.	96	105
510	500	47½x1	12 in.	18" "	85	95
710	700	47½x1	12 in.	18" "	85	95
810	Electric	12 in.	18" "	105	130

For half-hood on any of these forges add the letter H after the forge number and add 6 pounds to the weights. Clay hearths before using.

Buffalo

Buffalo Series 12 Rivet Forges

ONE-PIECE SEAMLESS STEEL HEARTH



Buffalo No. 812 Rivet Forge

A further indication of the extent to which we have gone to provide "the best" in forges for our customers is found in the number 12 series shown on this page. This forge has a deep-drawn heavy, one-piece steel hearth 24 inches in diameter. While our smaller one-piece hearths have been imitated, we are at present the only manufacturer to offer a 24" one-piece hearth. The cost of making dies to press out this heavy bowl was quite large, but when we saw the enormous difference in the old style and the new, we decided to make up the 24-inch hearth regardless of the expense.

Our faith in the excellence of this forge has been justified because it is today one of the most popular models.

On a forge with as large a hearth as 24 inches, it is important that the legs be of ample strength and properly spaced to prevent over-balancing. On the No. 12 series this is so well worked out that the forge is more solid than a three-legged forge, and much harder to over-balance. In fact, the whole forge is so well proportioned that it is a pleasure to use it.

Although rigid when assembled, the No. 12 series of forges is easily and quickly dismantled for transportation.

Four different blowers are available as indicated below.

Forge No.	Blower No.	Gear Ratio	Diam. of Fan Case	Hearth	Net Wgt.	Crated Wgt.
212	200	47½ to 1	12 in.	24" Dia.	115	125
512	500	47½ to 1	12 in.	24" "	100	120
712	700	47½ to 1	12 in.	24" "	100	120
812	Electric	12 in.	24" "	100	110

For half-hood on any of these forges add the letter H after the forge number and 8 pounds to the weights. Clay hearths before using.

Buffalo

Buffalo Series 35 Forges

ONE-PIECE, SEAMLESS, ALL-STEEL HEARTHHS



The Buffalo
No. 235 Forge.

The Series 35 forges with shallow, all steel hearths, were designed for light work of large size, and for this kind of service are particularly satisfactory.

The hearth is 24 inches wide, 30 inches long and 3 inches deep. Made from heavy gauge steel plate, there are no seams nor sharp corners to collect moisture and rust thru, and no joints to come apart. The top of the hearth is turned back to

form a broad flange, strengthening the whole forge and forming a convenient tool rest.

Legs are of heavy steel pipe, securely held in place with steel bracing so that there is no possibility of loosening. One of the advantages of construction of the No. 35 forges is found in the ease with which they can be "knocked down" and reassembled when necessary.

Four blowers can be had with the series 35 hearth as shown below.

Forge No.	Blower No.	Gear Ratio	Diam. of Fan Case	Hearth	Net Wgt.	Crated Wgt.
235	200	47½ to 1	12 in.	24x30x3	107	171
535	500	47½ to 1	12 in.	24x30x3	97	130
735	700	47½ to 1	12 in.	24x30x3	97	130
835	Electric	12 in.	24x30x3	102	137

For half-hood on any of these forges add the letter H after the forge number and add 10 lbs. to the weights. Water tanks furnished only when specified, and at extra charge. Clay hearths before using.

Buffalo

Buffalo Series 36 Forges

DEEP, HEAVY, SEAMLESS, ONE-PIECE STEEL HEARTHHS



Buffalo No. 236-H Forge

There is always a need for a deep hearth forge for certain kinds of work and the No. 36 all-steel forge was designed with that in mind. A full 6 inches deep, 24 inches wide, and 30 inches long, made from a single heavy sheet of steel, no other forge can offer so much in light weight, strength, portability, and large capacity.

Legs are heavy angle iron, bolted securely to the deep hearth, and effectively strengthened with steel cross braces. Blowers are mounted on a substantial bracket.

The Buffalo "Vulcan" Tuyere is supplied on the No. 36 series of forges. This is described fully on page 16.

Forge No.	Blower No.	Gear Ratio	Diam. of Fan Case	Hearth	Net Wgt.	Crated Wgt.
236	200	47½ to 1	12 in.	24x30x6	117	181
536	500	47½ to 1	12 in.	24x30x6	107	140
736	700	47½ to 1	12 in.	24x30x6	107	140
836	Electric	12 in.	24x30x6	112	147

For Half-Hood on any of these forges add the letter H after the forge number and 10 pounds to the weights.

Water tanks furnished only when specified and at extra charge.

Clay hearths before using.

"Buffalo"

Buffalo Series 43 Forges

WITH CAST IRON HEARTH

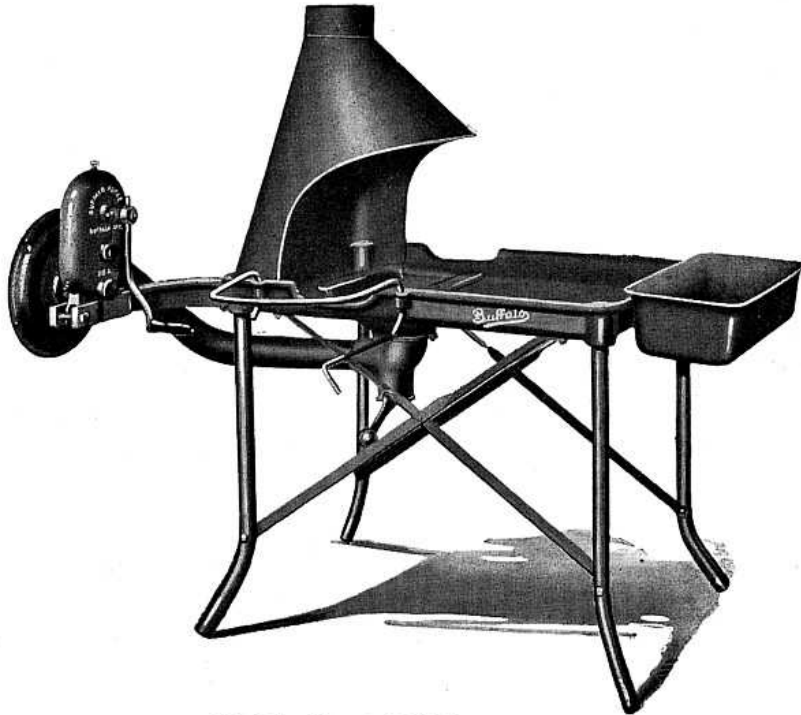

Buffalo No. 243-H Forge

In the revised line of forges shown in this catalog only three cast iron hearths are retained, principally for use where light weight is unimportant. Of these the No. 43 shown here is the most popular.

Garages, general repair shops, street railways and similar shops use many No. 43 hearths with the No. 200 blower as shown here, the finest outfit obtainable for their work.

Heavy steel pipe legs are used on the No. 243, securely strengthened with steel cross braces. Buffalo Vulcan Tuyere is supplied.

Down-Draft Hood

When desired, the down-draft hood shown at right can be furnished. This hood is so arranged that the rising gases are drawn back into the blower and thus improve combustion.



Buffalo No. 243-E Down-Draft Forge

Forge No.	Blower No.	Gear Ratio	Diam. of Fan Case	Hearth	Net Wgt.	Crated Wgt.
243	200	47½ to 1	12 in.	28x40	260	300
543	500	47½ to 1	12 in.	28x40	250	290
743	700	47½ to 1	12 in.	28x40	250	290
843	Electric	12 in.	28x40	260	300

For half-hood on any of these forges add the letter H after the forge number and 5 pounds to the weights.

For down-draft hood on No. 243 and 843 add letter E and 250 pounds to the weights.

Water tanks furnished only when specified and at extra charge.

Clay hearths before using.

Buffalo

Buffalo Series 48 and 49 Forges

WITH CAST IRON HEARTH

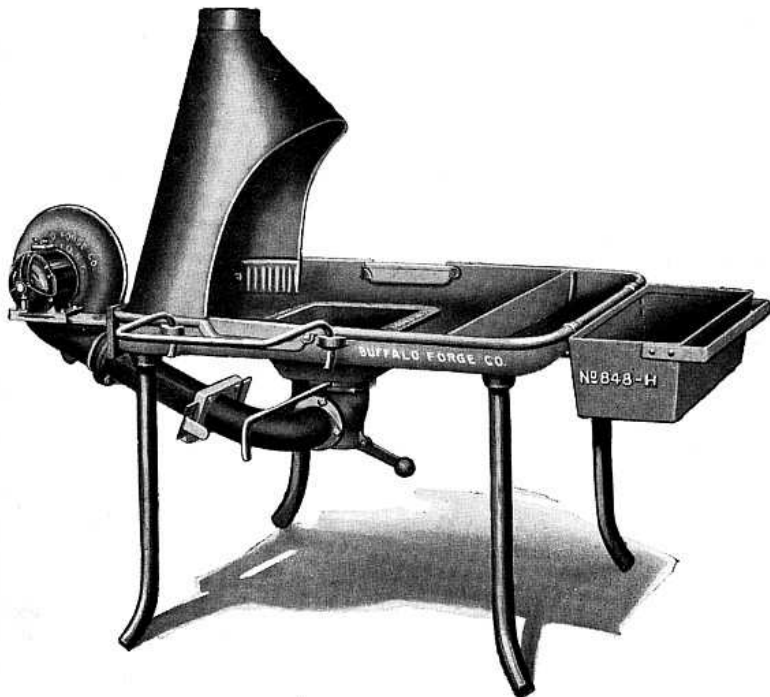

Buffalo No. 848-H Forge with Electric Blower

The No. 48 and 49 cast iron hearths are used for the heaviest kind of blacksmith work, in railroad shops, truck and bus garages.

Very heavy, cast iron construction with extra large steel pipe legs, anchored at the top in pockets cast on the hearth.

The No. 48 hearth is 38x42 inches by 3 inches deep, and weighing 415 lbs. is semi-portable. Removable iron partition is arranged to serve as coal box.

No. 49 is the same length and width, but is 6 inches deep, to fill the need for a larger fire for very heavy work. The hearth may be lined with fire brick if desired.

Both of these forges can be equipped with the down-draft hood shown on page 10.

Forge No.	Blower No.	Gear Ratio	Diam. of Fan Case	Hearth	Net Wgt.	Crated Wgt.
248	200	47½ to 1	12 in.	38x42x3	345	415
548	500	47½ to 1	12 in.	38x42x3	335	405
748	700	47½ to 1	12 in.	38x42x3	335	405
848	Electric	12 in.	38x42x3	345	415
249	200	47½ to 1	12 in.	38x42x7	540	610
549	500	47½ to 1	12 in.	38x42x7	520	590
749	700	47½ to 1	12 in.	38x42x7	520	590
849	Electric	12 in.	38x42x7	540	610

For half-hood on any of these forges add the letter H after the forge number and 10 pounds to the weights.
 For down-draft hood on Nos. 248 and 848 add letter E and 325 pounds to the weights.
 Water tanks furnished only when specified and at extra charge.
 Clay hearths before using.

Buffalo

The Famous "Bufco" Forges

"Buffalo Forge Company's distinctive accomplishment in the way of light forges."

An accurately stamped steel gear and fan case furnish air for our standard drawn steel hearths. Bronze bushings are used thruout, the fan has a 5½ inch pressed steel wheel.

The Bufco forges are particularly suited to agricultural implement work, occasional repair work and rivet heating demanding easy portability.

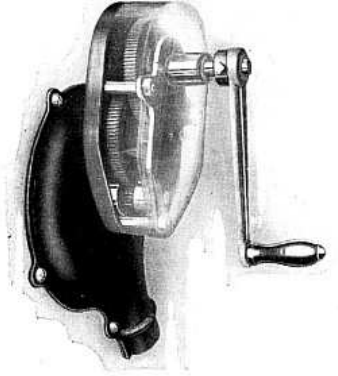

Bufco Nos. 061 and 062 Forges



Bufco No. 061

These forges are now made with a heavy one-piece drawn steel hearth, perfectly formed, without seams or corners to collect moisture and rust. The hearth is stronger and more durable than cast iron, and is considerably lighter.

The forge is mounted on three strong jointed legs and will stand firmly on uneven ground. The Bufco blower described above is regularly furnished. Shipping costs are low because these forges are knocked down and shipped in cartons.



Bufco 062-H

No.	Size of Hearth	Hood	Wgt. Packed in Carton
061	18 in. dia., 3 in. deep	Windshield	48 lbs.
061-H	18 in. dia., 3 in. deep	Half-hood	52 lbs.
062	24 in. dia., 3 in. deep	Windshield	56 lbs.
062-H	24 in. dia., 3 in. deep	Half-hood	58 lbs.

Bufco Bench Forge

A sturdy little outfit made up for use on a bench, or where a forge is frequently transported from place to place. The one-piece steel plate hearth is mounted on a short pedestal. No. 7 has steel windshield, No. 8 has half-hood.

No.	Hearth	Shipping Wgt. with Case	Without Case
7	18 in. dia.	70 lbs.	40 lbs.
8	18 in. dia.	72 lbs.	42 lbs.

Clay hearths before using.

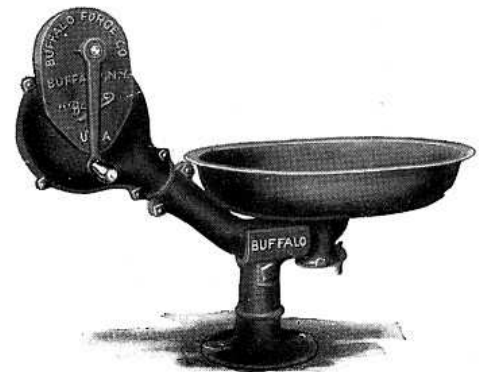

Buffalo

Buffalo Compressed Air Forges



Buffalo No. 010

The forge shown here is an entirely re-designed model; stronger, lighter, better-looking than the old style.

Hearths are the Nos. 10 and 12 described on pages 6 and 7, mounted on well-braced steel pipe legs. One-piece seamless construction of the hearth guarantees long life.

This forge is operated by compressed air at any pressure available from 15 to 100 lbs. A simple needle valve provides for easy regulation of blast, and once adjusted, this valve requires no further attention. The compressed air is fed to the fire thru a specially made three stage injector. In stages one and two, five volumes of outside air are drawn in to each volume of compressed air. In the third stage the air is mixed and reduced to proper pressure for the fire.

Made in two sizes only.

No. 010 Compressed Air Forge	18" dia. Hearth.	Net Wgt. 34 lbs.	Crated Wgt. 50 lbs.
No. 012 Compressed Air Forge	24" dia. Hearth.	Net Wgt. 39 lbs.	Crated Wgt. 60 lbs.

Clay hearths before using.

Buffalo

Buffalo Oil-Burning Forges

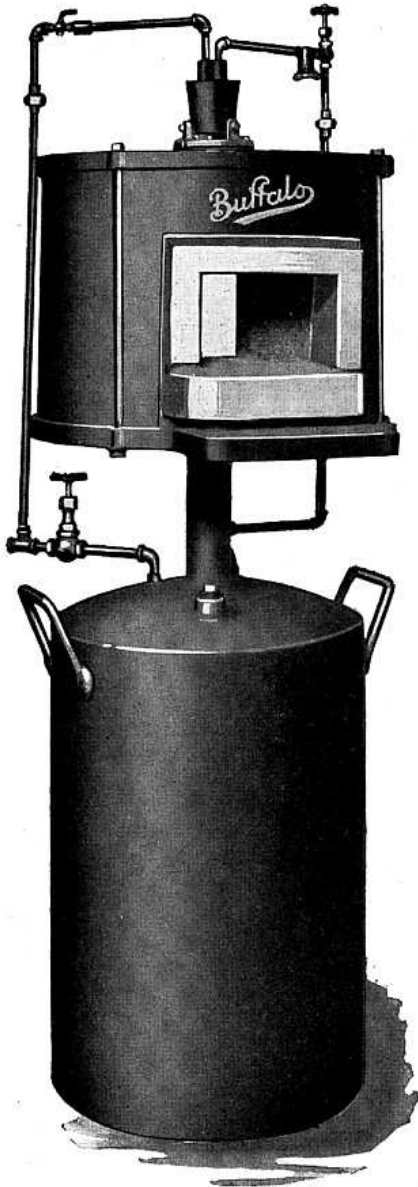

Buffalo No. 3 Oil-Burning Rivet Forge.

Probably the most easily controlled and safest method of heating rivets where compressed air is available. With these forges there are no sparks, rivets are always in plain view and held at the proper temperature. Impossible to burn rivets with these forges.

The tank is of welded steel, with steel fire chambers lined with 2 inches of refractory material of the best quality. To replace worn-out linings it is only necessary to unscrew three nuts and lift the top off the fire chamber.

Air is supplied to the tank thru a single connection which furnishes pressure for the oil supply as well as air for the atomizer. Burns kerosene, distillate or any fuel oil.

Nos. 1 and 2 forges are open at the front only, while No. 3 has an opening all the way thru so that long stock can be heated. A block of fire brick is provided to close the back of forge when heating rivets.

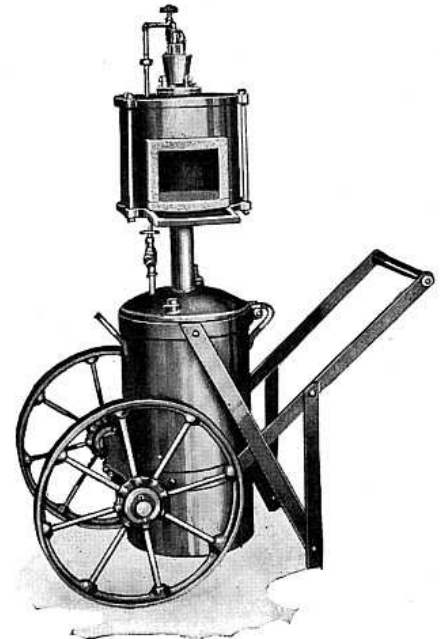

No. 1 Forge mounted on truck making an ideal portable unit for factories and construction jobs.

SPECIFICATIONS

	No. 1	No. 2	No. 3
Height to top of chamber	43 in.	45 in.	45 in.
Height of chamber	11½ in.	14½ in.	14½ in.
Inside diameter	7 in.	10 in.	10 in.
Inside height	6 in.	8 in.	8 in.
Fire opening	3½ x 5¼ in.	4x6 in.	4x6 in.
Capacity of tank	12 gal.	18 gal.	18 gal.
Shipping Wgt.	175 lbs.	260 lbs.	260 lbs.
Shipping Wgt. with Truck	235 lbs.	320 lbs.	320 lbs.

"Buffalo"

Buffalo Hand and Electric Blowers

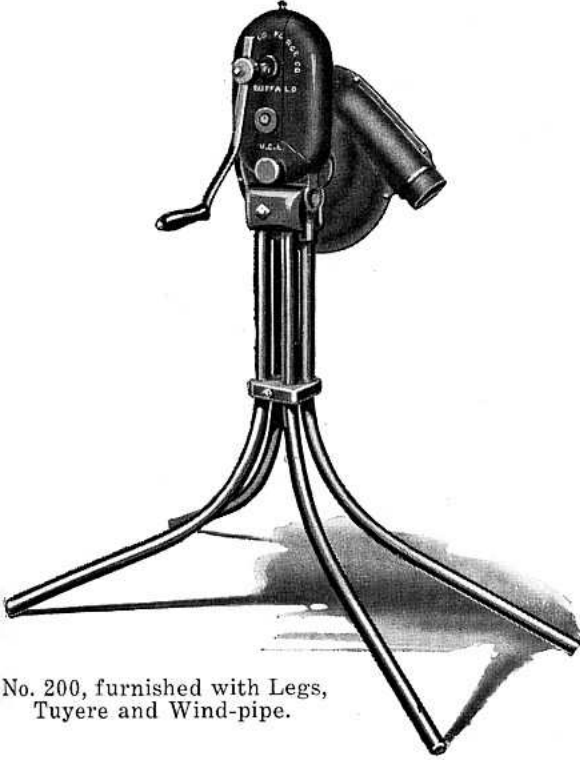

No. 200, furnished with Legs, Tuyere and Wind-pipe.

No. 200 Hand Blower on Legs—

The popular No. 200 blower head described on page 4, mounted on four strong steel pipe legs. Supplied with "Vulcan" tuyere and two 19-inch lengths of 3 inch pipe and elbow the same as shown with the No. 500 below.

Nos. 500 and 700 Blowers on Pedestals—

The 500 and 700 Blowers are described fully on page 4. Supplied as shown here with "Vulcan" tuyere, and pipe with elbow, or can be furnished with legs same as No. 200.



Electric Blowers—

These small forge fire blowers are also used on small furnaces, church organs, etc. Motor is variable speed, ball-bearing. Several feet of wire, plug and six-speed regulator are supplied. Operates on 25, 30, 40, 50 or 60 cycle and for 110 or 220 volts only.

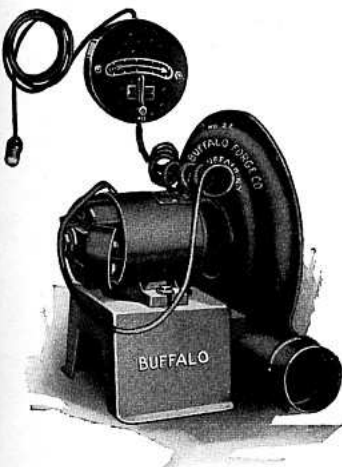

No. 2-E Electric Blower with variable speed motor and six speed regulator

Buffalo Hand Power Blowers

No.	Type of support	Net Wgt.	Crated Wgt.
200-L	Legs	123 lbs.	133 lbs.
500-L	Legs	110 lbs.	125 lbs.
500-P	Pedestal	100 lbs.	115 lbs.
700-L	Legs	62 lbs.	70 lbs.
700-P	Pedestal	100 lbs.	115 lbs.

Buffalo Electric Blowers (Variable Speed)

No.	Wgt.	R.P.M.	Dia. of Outlet	Total Hgt.
2-E	38 lbs.	2600	3 in.	15 in.
2-EH	40 lbs.	3400	3 in.	15 in.

Buffalo Electric Blowers (Constant Speed)

2-E	50 lbs.	1750	3 in.	15 in.
2-EH	55 lbs.	3000	3 in.	15 in.
3-E	90 lbs.	3400	4 in.	17 in.
4-E	110 lbs.	3400	5 in.	20 in.

When ordering specify whether 110 Volt or 220 Volt regulator is wanted.

Buffalo

Buffalo Tuyeres



Vulcan



Climax



RR

The Buffalo Vulcan Tuyere was designed for general all around blacksmith work. Eccentric blast valve gives a wide range of regulation as follows:

With the small opening of the tuyere the blast is forced into the fire pot through three tapering converging channels, giving a large deep fire.

A quarter turn of the rod brings the valve to a position suitable for a small fire at either side of the fire-pot.

It is very easy because of the rising and falling action of the valve to break up clinkers and clear the fire-pot making cleaning out from the top unnecessary.

This tuyere when used with the No. 200 Blower has nearly three times the welding capacity of any other standard type tuyere on the market. It takes four-inch iron up to 12 inches long in one heat without moving the iron.

Climax—has revolving clinker-breaker valve. Sliding cover at bottom for removing ashes.

RR—This tuyere has clinker-breaking valve, also hinged and balanced ash gate, which opens and closes by a touch of the foot.

EE—The bowl of this tuyere is bolted on, and can be removed when desired. A twist of the seven-inch ball valve breaks up the clinker, which falls thru the large slot in bottom of ball. This valve is also used for regulating the size of the fire.

JJ—This tuyere has same features as the EE described above and in addition has a blast gate at the side.

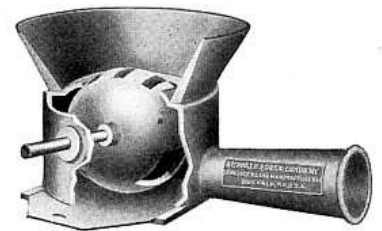

EE

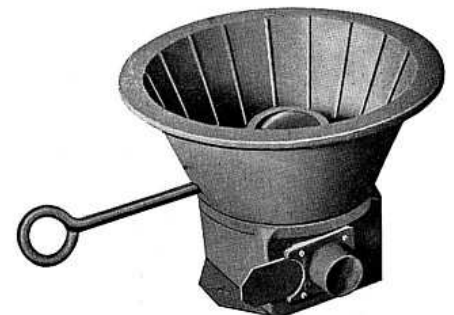

JJ

SPECIFICATIONS

Name	Size of Bowl	Blast Pipe Diam.	Depth of Fire Pot	Crated Wgt.
Vulcan	12½x14 in.	3 in.	4½ in.	55 lbs.
Climax	8x 7 in.	3 in.	30 lbs.
RR	12x14 in.	3 in.	5 in.	85 lbs.
EE	11 in. diam.	3 in.	4 in.	80 lbs.
JJ	18 in. diam.	3 in.	8 in.	179 lbs.

Buffalo

Buffalo Stationary Forges

TELESCOPIC AND STATIONARY HOODS

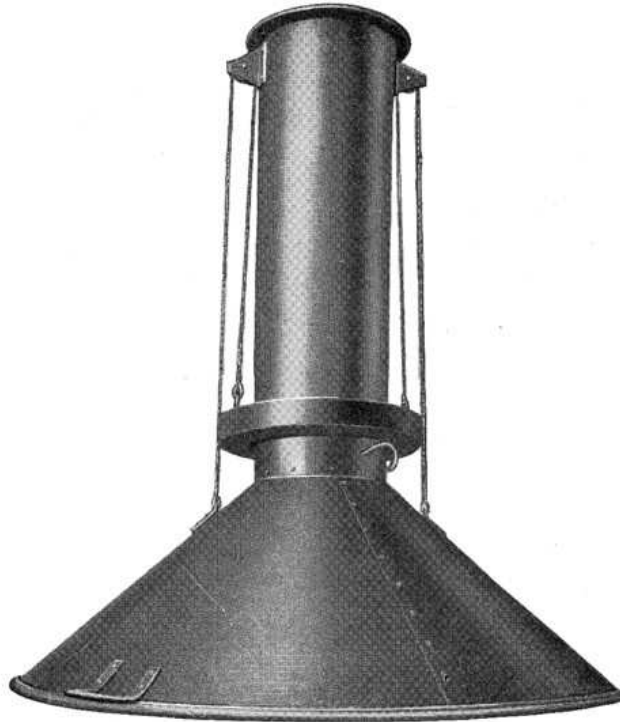

For the stationary forges described on the following pages we furnish, when desired, telescopic hoods of the design shown above. These hoods are made of heavy sheet steel, reinforced around the rim of hood and at the ends of the telescopic sections. Counterweight, pulleys and wire rope are included.

We also supply a stationary hood, consisting merely of the canopy with a narrow collar around the top, leaving it to the purchaser to provide vertical pipe connection of a height to suit his shop.

Telescopic Hood No.	Over-all Diameter	Diameter of Pipe	Maximum Length Pulled Down	Minimum Length	Crated Weight
1T	26 in.	9 in.	75 in.	50 in.	70 lbs.
2T	30 in.	10 in.	75 in.	50 in.	75 lbs.
3T	40 in.	11 in.	80 in.	56 in.	110 lbs.
4T	51 in.	12 in.	83 in.	56½ in.	145 lbs.

Stationary Hood No.	Diameter Over-all	Diameter of Collar	Crated Weight
1S	26 in.	9 in.	20 lbs.
2S	30 in.	10 in.	25 lbs.
3S	40 in.	11 in.	35 lbs.
4S	51 in.	12 in.	50 lbs.

Buffalo

Semi-Portable Forges



Buffalo
No. 36-H
Forge

These forges are of the semi-portable type that has great adaptability for many shops. The hearths are the same as those listed under the same numbers among the portable forges, but in place of blowers, are equipped with dumping tuyeres and blast connections for air supply from power blowers. The extra heavy construction and bracing of these forges permits handling and hard usage without damage.

The blast connections are 3" in diameter, and are fitted with a lever-controlled blast gate.



Stationary Forge No. 49



Cast Iron Semi-portable
Forge No. 43-H

No.	Construction	Size of Hearth	Kind of Tuyere	Kind of Hood	Crated Weight
35-H	Steel	24 x 30 x 3	Round Pot	Half Hood	120 lbs.
36-H	Steel	24 x 30 x 6	Vulcan	Half Hood	130 lbs.
43-H	Cast Iron	28 x 40	Vulcan	Half Hood	240 lbs.
48-H	Cast Iron	38 x 42 x 3	R. R.	Half Hood	340 lbs.
49-H	Cast Iron	38 x 42 x 7	R. R.	Half Hood	360 lbs.

Water Tanks Extra Equipment

Clay hearths before using.

Buffalo

Stationary Forges Nos. 85 and 86

This forge is designed and built for heavy work.

Built of heavy steel plate, rigidly stiffened and strengthened throughout to meet every strain of service. The edges are reinforced. The hearth may be lined with clay to reduce heat radiation through the sides.

Regularly equipped with anti-clinker dumping tuyere, and blast gate. Steel coal box and water tank can be furnished, if desired, at extra cost.

The No. 85 has a 3 inch and No. 86 a 4 inch blast connection.

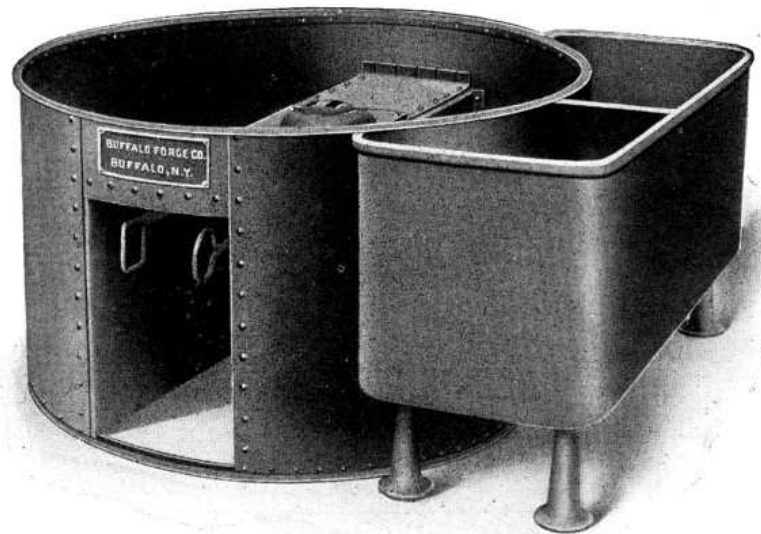

No.	Diameter of Hearth	Kind of Tanks	Size of Coal Box	Size of Water Tank	Net Weight
85	36 in.	Steel Plate	15 x 10 x 20 in.	18 x 10 x 15 in.	300 lbs.
86	48 in.	" "	20 x 13 x 18 in.	25 x 13 x 18 in.	400 lbs.

Clay hearths before using. Water tanks extra equipment.

Stationary Forges Nos. 885 and 886

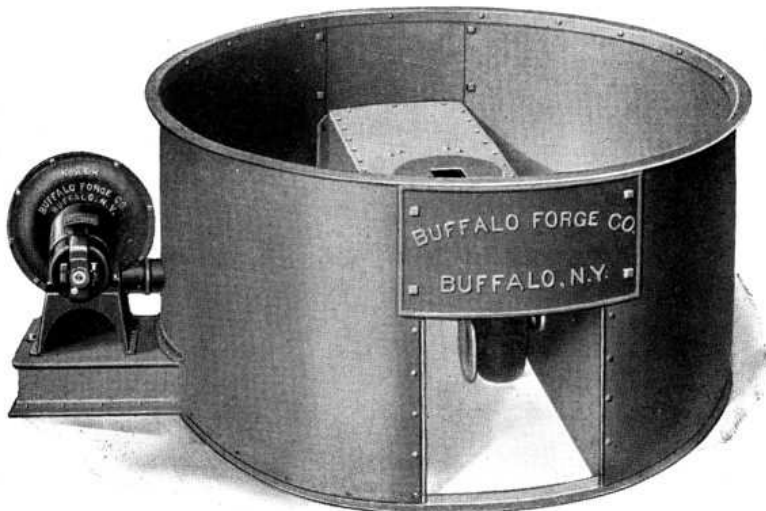

These are the Nos. 85 and 86 forges equipped with individual electric blower, otherwise the same construction.

The forge may be set in the location most convenient, without any reference to line shafts, pulleys or the requirements of belting. When placed in position, connections are made by running the wires to the nearest electric circuit. When not in use the current is shut off and no power wasted.

Fitted with Variable or Constant Speed Electric Blower, mounted inside of forge casing, and easily accessible thru door in side of forge, and protected. For convenience, the illustration shows blower outside.

Tanks will be furnished if desired.

No.	Height to top of Fire Pan	Diameter of Fire Pan	No. Electric Blower	Net Weight
885	26 in.	36 in.	2E	375 lbs.
886	26 in.	48 in.	2EH	440 lbs.

Water tanks extra equipment.

Clay hearths before using.

Buffalo

Stationary Forge No. 97

This forge is especially adapted for the heaviest forge shop work. It was originally designed for the shops of the Union Pacific R. R. Co.

The hearth is made of cast iron and is 8 inches deep, but the two gates, one on each side, when opened, lower the sides of the hearth 4 inches. A coal box and water tank are at one end and integral with the hearth. Legs are cast iron.

Furnished regularly with improved tuyere of extra heavy construction, a 4 inch blast connection and lever controlled blast gate.

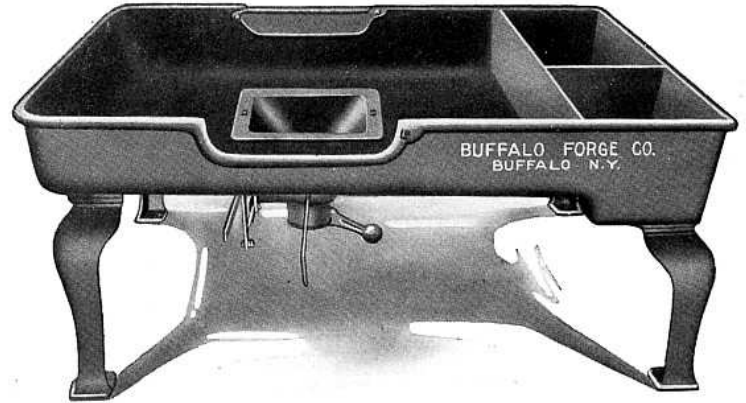

No.	Size of Hearth	Height to Top of Forge	Depth of Fire Pit	Blast Connections	Crated Weight
97	49½ x 56½ in.	26½ in.	8 in.	4 in.	955 lbs.

Clay hearths before using.

Stationary Forge No. 98

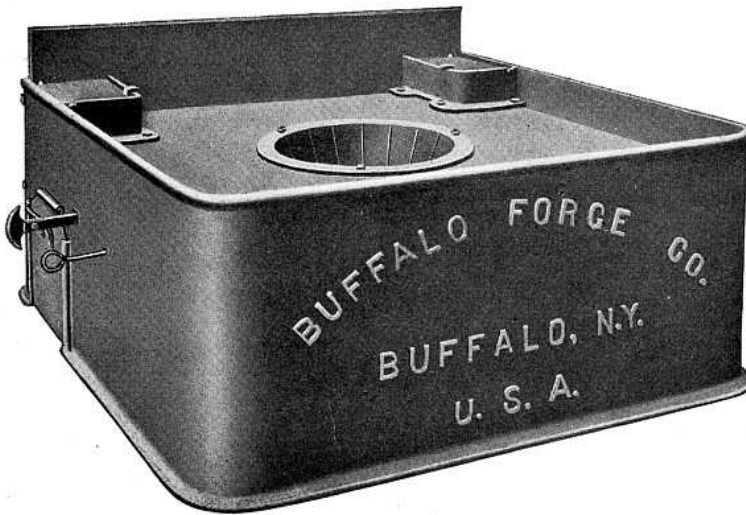

This type of forge will handle extremely heavy work and is a splendid forge for large railroad shops where it is necessary to spring locomotive frames and similar heavy and difficult work. It is advisable to install one of these forges in a shop equipped for light work, to handle heavy work that may come in from time to time.

The frame and hearth are made of cast iron. The fire pot is 8 inches deep while the depth of the fire pan is 4 inches, making a total depth of 12 inches.

Regularly equipped with extra heavy Buffalo anti-clinker tuyere and improved blast gate.

No.	Size of Hearth	Height to Top of Hearth	Depth of Fire Pit	Blast Connections	Crated Weight
98	54 x 54 in.	24 in.	8 in.	4 in.	1165 lbs.

Clay hearths before using.

Buffalo

Buffalo Hand and Power Drills

DISPLAYED in the following pages are the drills which users have selected as the most popular numbers we have built.

Each and every one of these machines has been designed and made according to basic "Buffalo" requirements as to strength, ruggedness and ability to stand the continuous service demanded by equipment of this type.

Buffalo 25-inch Back-gearred Upright Power Drill

This machine, the largest power drill made by us, has eight speeds and four power feeds, hand and lever feeds.

The sleeve bearing is split and adjustable for wear. The ground spindle has ball bearing thrusts and graduated sleeve. The hand feed lever is adjustable, 6 to 18 inches and is held in place by a tension spring. The worm feed wheel runs in oil and is latch-hinged. All gears are machine cut and made extra heavy. The large crown gear is made of high grade cast iron and runs on a heavy bronze bushing. The screw that operates the table has a ball thrust and is lathe turned. The table arm is drilled by the machine itself, assuring accuracy, while the base and table are T-slotted and planed. Tapping attachment extra. (See page 30.)

All Buffalo drills are tested in operation before leaving the factory and are guaranteed to be satisfactory in every respect.

SPECIFICATIONS

Height of drill 85 inches
Capacity—holes up to $1\frac{3}{4}$ in.
Drills to center of 25 in. circle
Greatest distance base to spindle $44\frac{1}{4}$ in.
Greatest distance table to spindle 30 in.
Travel of spindle $14\frac{1}{2}$ in.
Size of tight and loose pulleys $10 \times 3\frac{1}{8}$ in.
Speed of drive pulleys 300 R.P.M.
Spindle speeds, Direct, 365, 195, 110, 58.
Spindle speeds, Back-gearred, 70, 38, 22, 12.
Smallest diameter of cone pulleys 4 in.
Largest diameter of cone pulleys 10 in.
Floor space 20×59 in.
Regularly furnished for No. 4 Morse Taper Drills; can also be furnished for No. 3 Morse Taper Drills.
Style—25 in. back-gearred with W. & A. feed and stop. Net weight 1610 lbs., Crated weight 1780 lbs.

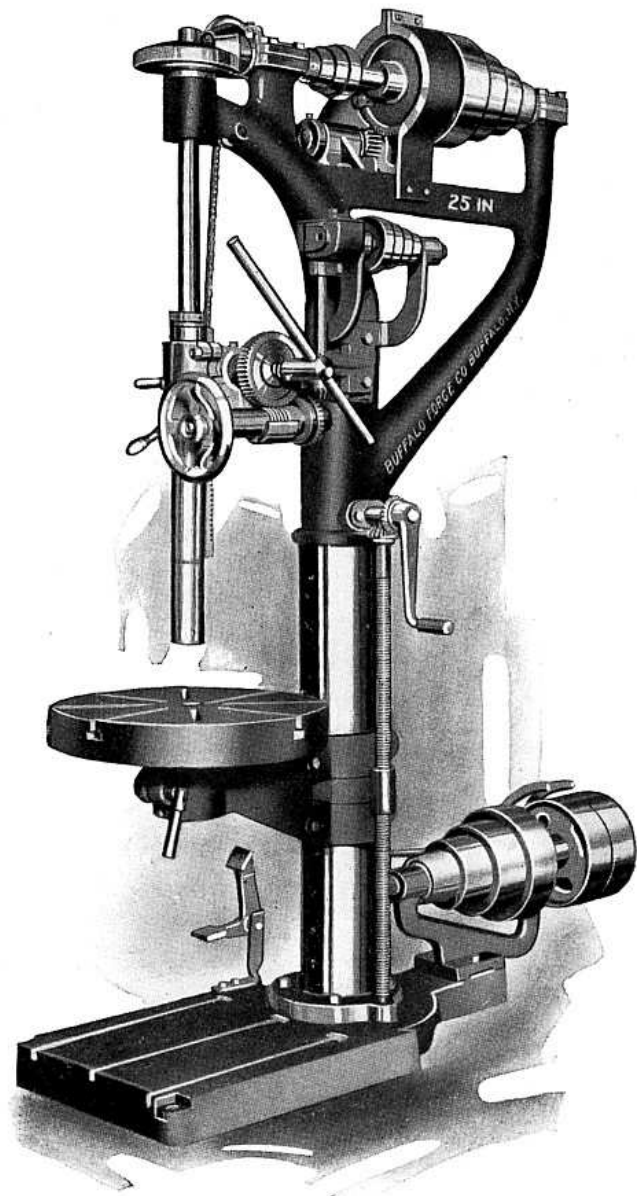

This drill can be instantly changed from plain to back-gearred drive without using a wrench by disengaging a knurled knob in the top gear and throwing in back gears by means of a hand lever. Locking screw is also provided to hold this arrangement in place. An adjustable automatic trip throws out power feed instantly when piece has been drilled to required depth.

Buffalo

Buffalo 24-inch Back-geared Upright Power Drill

This machine is built with the same skilled workmanship as employed on all of the Buffalo Power Drills and makes a first class machine shop tool.

The spindle is accurately ground and the sleeve ground and graduated. Spindle has ball bearing thrust. The lever handle is adjustable from 6 to 18 inches and is held in place by a tension spring. The sleeve bearing is split and adjustable for wear. The worm feed gear runs in a continuous bath of oil and is latch-hinged. The crown gear is made of cast iron and runs on heavy bronze bushing.

This drill can be easily changed from plain to back-geared drive without using wrench, by disengaging a knurled knob in the top gear and engaging back gears by means of hand lever. A locking screw is provided to hold this in place. An adjustable automatic trip throws out power feed when piece has been drilled to required depth.

Can be furnished direct connected to motor. Tapping attachment furnished at extra charge. (See page 30.)

SPECIFICATIONS

Height of drill 83 in.
Capacity—holes up to $1\frac{1}{2}$ in.
Drills to center of 24 in. circle
Greatest distance base to spindle $43\frac{1}{2}$ in.
Greatest distance table to spindle 27 in.
Travel of spindle $14\frac{1}{4}$ in.
Travel of table 28 in.
Diameter of table $16\frac{3}{8}$ in.
Size of tight and loose pulleys 8 x 3 in.
Speed of drive pulleys 300 R.P.M.
Spindle Speeds, Direct, 368, 211, 127, 72
Spindle Speeds, Back-geared, 72, 41, 25, 15
Smallest diameter of cone pulleys 4 in.
Largest diameter of cone pulleys 9 in.
Floor space 47 x 16 in.
Net weight, 1100 lbs.
Crated weight, 1270 lbs.
Regularly furnished for No. 4 Morse Taper Drills; can also be furnished for No. 3 Morse Taper Drills.

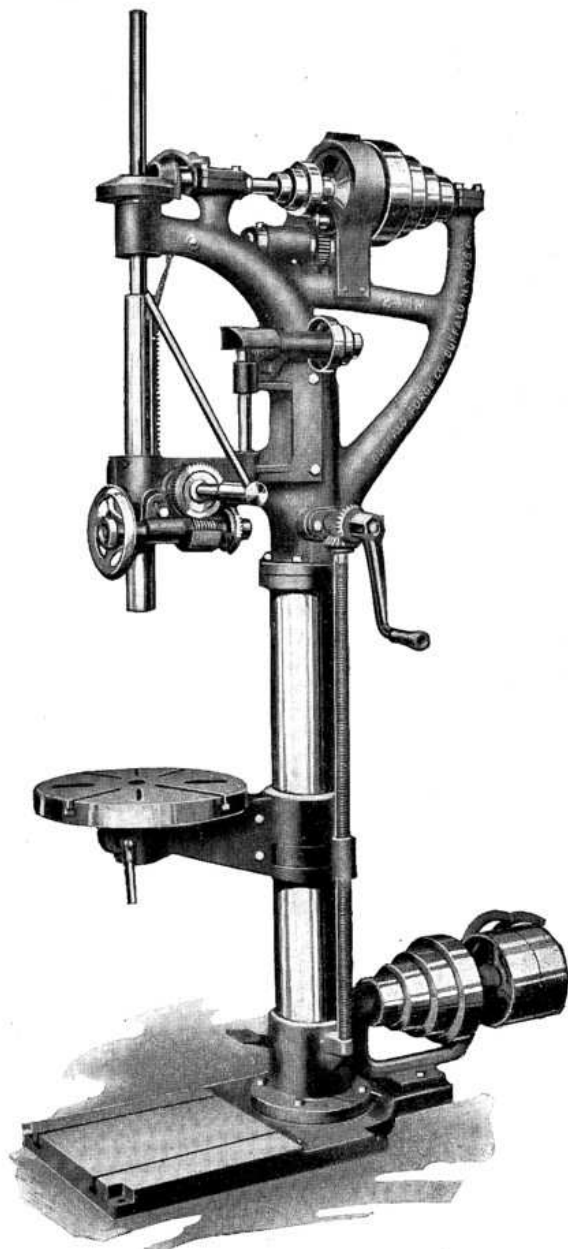

This drill has practically all of the advantages of higher priced drills, drilling to the center of a 24 inch circle, with a spindle travel of $14\frac{1}{4}$ ", and is well suited to handle cylinder re boring work.

Buffalo

Buffalo 21-Inch Back-geared Upright Power Drill

WITH GEAR-DRIVEN FEED

A big, well-balanced and powerful drill with eight speeds, three power feeds and hand and ratchet lever feeds. The power feed is gear-driven, according to the most improved practice, and is silent and durable.

The spindle has a travel of 12½ inches, which is unusually long. The drill is also arranged so that it can be changed instantly from plain to back-geared drive without using a wrench, by disengaging a knurled knob in the top gear and engaging back gears by means of hand lever. A locking screw is provided to hold this lever in place.

An adjustable, automatic trip throws out the power feed instantly when the piece has been drilled to the required depth.

The sleeve bearing is split and adjustable for wear. The ball bearing spindle is ground—with graduated sleeve. The gears are machine cut, very heavy and guarded. A bath of oil lubricates the latch-hinged worm feed gear. The large crown gears, accurately machined, run on bronze bushing. The screw that operates the table has ball thrust and is lathe turned. The table arm is drilled by the machine itself, assuring accuracy. The base and table are T-slotted and planed, making set-ups very easy.

Can be furnished direct connected to motor. Tapping attachment furnished at extra charge. (See page 30.)

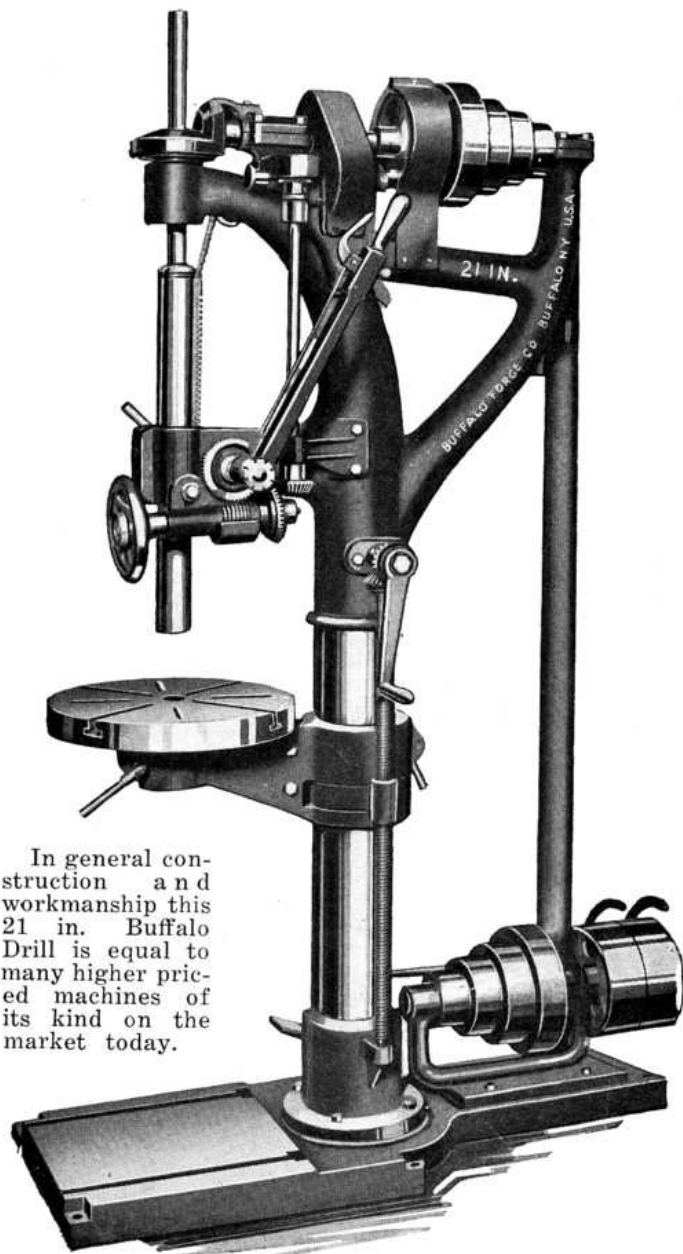

In general construction and workmanship this 21 in. Buffalo Drill is equal to many higher priced machines of its kind on the market today.

SPECIFICATIONS

Height of drill, 74 in.
Capacity—holes up to 1½ in.
Drills to center of 21 in. circle
Greatest distance base to spindle, 39 in.
Greatest distance table to spindle, 22 in.
Travel of spindle 12½ in.
Spindle speeds, direct 368, 211, 127, 72
Spindle speeds, back-geared, 72.2, 41.4, 24.9, 14.3
Feed per 1 rev. of spindle, .011, .0072, .0047
Diameter of table, 16½ in.

Size of tight and loose pulleys, 8 x 3 in.
Speed of drive pulleys, 300 R.P.M.
Smallest diameter of cone pulleys, 4 in.
Largest diameter of cone pulleys, 9 in.
Floor space, 16 x 47 in.
Depth of cone pulley steps, 2½ in.
Net weight, 1100 lbs. Crated weight, 1200 lbs.
Regularly furnished for No. 4 Morse Taper. Can also be furnished for No. 3 Morse Taper.

Buffalo 20-inch Back-geared Upright Power Drill

The Buffalo 20 in. Drill has eight speeds and three power feeds as well as hand feed and ratchet lever feed.

It can also be instantly changed from plain to back-geared drive without using wrench by disengaging knurled knob in the top gear and throwing in back gears by means of hand lever. A locking screw is also provided to hold this in place.

An adjustable automatic trip throws out power feed instantly when piece has been drilled to required depth.

The sleeve bearing is split and adjustable for wear; the accurately ground spindle has ball bearing thrust and graduated sleeve. The worm feed gear runs in bath of oil and is latch hinged. All gears are machine cut, (extra heavy). Large crown gear is made of high grade cast iron and runs on heavy bronze bushing. The screw that operates table has ball thrust and is lathe turned. Table arm drilled by machine itself, assures accuracy. The base and table are T-slotted and planed.

Can be furnished direct connected to motor. Tapping attachment furnished at extra charge. (See page 30.)

SPECIFICATIONS

Height of drill 74 in.
 Capacity—holes up to 1½ in.
 Drills to center of 20 in. circle.
 Greatest distance base to spindle 41 in.
 Greatest distance table to spindle 25 in.
 Travel of spindle 8½ in.
 Diameter of table 16½ in.
 Size of tight and loose pulleys 8 x 3 in.
 Speed of drive pulleys 300 R.P.M.
 Spindle Speeds, Direct, 368, 211, 127, 72
 Spindle Speeds, Back-geared, 72, 41, 25, 15
 Smallest diameter of cone pulleys 4 in.
 Largest diameter of cone pulleys 9 in.
 Floor space, 16 x 47 in.
 Depth of cone pulley steps 2¼ in.
 Regularly furnished for No. 4 Morse Taper. Can also be furnished for No. 3 Morse Taper.

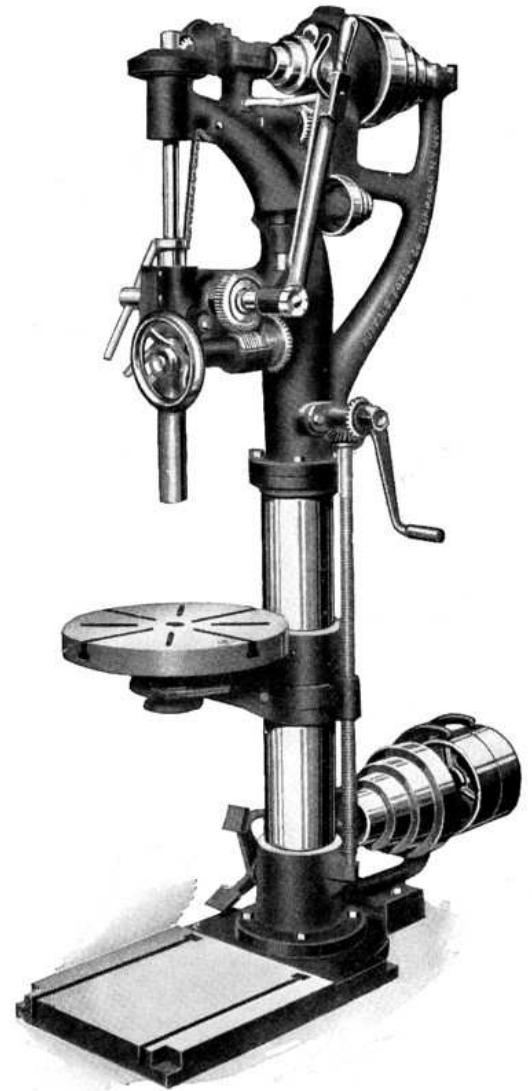

All of our drills are built complete in every respect from pattern shop to packing crate in our large, modern factory by skilled workmen who have been building Buffalo Drills for many years.

This machine made up in five different styles.

Style	Net Weight	Crated Weight
No. 1—20 in. Plain Lever Feed	685 lbs.	790 lbs.
No. 2—20 in. Lever and Wheel Feed	730 lbs.	835 lbs.
No. 3—20 in. Lever-Wheel-Automatic Feed and stop	865 lbs.	970 lbs.
No. 4—20 in. Back-geared with wheel and lever feed	875 lbs.	980 lbs.
No. 5—20 in. B. G. with W. and A. F. and Stop	900 lbs.	1000 lbs.

Buffalo

Buffalo 16-inch Bench and Floor Production Drills

With S K F Ball Bearings and 7" Spindle Travel

These new sensitive, motor driven drills, appearing for the first time in this catalog, are the perfected result of more than a year's experimental work. Sturdy beyond actual requirements, accurate in every respect, powerful enough to be fast and easy to handle, the 16-inch Bench and Floor Drills are an exceptional value.

Three spindle speeds are provided, 418, 835 and 1725 R.P.M. SKF ball bearings are used throughout. Hand lever and foot treadle feed are provided for speed and convenience. Head has a travel of 8½ inches, while spindle travel is 7 inches.

Complete detailed specifications given below:

SPECIFICATIONS

Capacity of both models:

½ H.P. Motor. In steel, ⅜" hole; cast iron, ⅝" hole.
 ½ H.P. Motor. In steel, ⅜" hole; cast iron, ⅞" hole.
 Motor Speed, 1725 R.P.M.

16-INCH BENCH DRILL

Height, 48 in.
 Drills to center of 16 in. circle.
 Greatest distance table to spindle, 28 in.
 Travel of spindle, 7 in.
 Table stationery
 Adjustment of head, 8½ in.
 Cone pulley on motor, 2¼ in., 3¾ in., and 5¾ in. diameter.
 Belt, 2 in. wide.
 Cone pulley on spindle, 5¾ in., 7¾ in. and 9¼ in. diameter.
 Base of table, 15¾ x 22½ in.
 Base of table working surface, 12¾ x 12¾ in.
 Spindle bored for No. 2 Morse Taper.
 SKF bearings throughout.
 Steel column, 4 in. diameter.
 Net weight, 350 lbs.
 Furnished with quick return and with or without foot treadle.

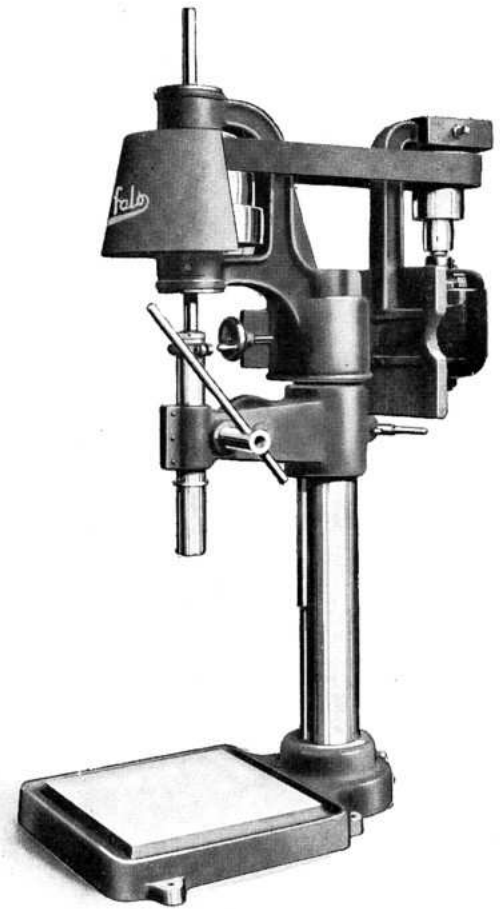

Buffalo 16-inch Bench Drill

16-INCH FLOOR DRILL

Height, 76 in.
 Drills to center of 16 in. circle.
 Greatest distance base to spindle, 46 in.
 Greatest distance table to spindle, 38 in.
 Travel of spindle, 7 in.
 Adjustment of head, 8½ in.
 Tilting table, 12 in. square.
 Cone pulley on motor 2¼ in., 3¾ in. and 5¾ in. diameter.
 Cone pulley on spindle, 5¾ in., 7¾ in. and 9¼ in. diameter.
 Floor base, 21 in. diameter.
 Steel column, 4 in. diameter.
 Spindle bored for No. 2 Morse Taper.
 Net weight, 400 lbs.
 Furnished with quick return and with or without foot treadle.

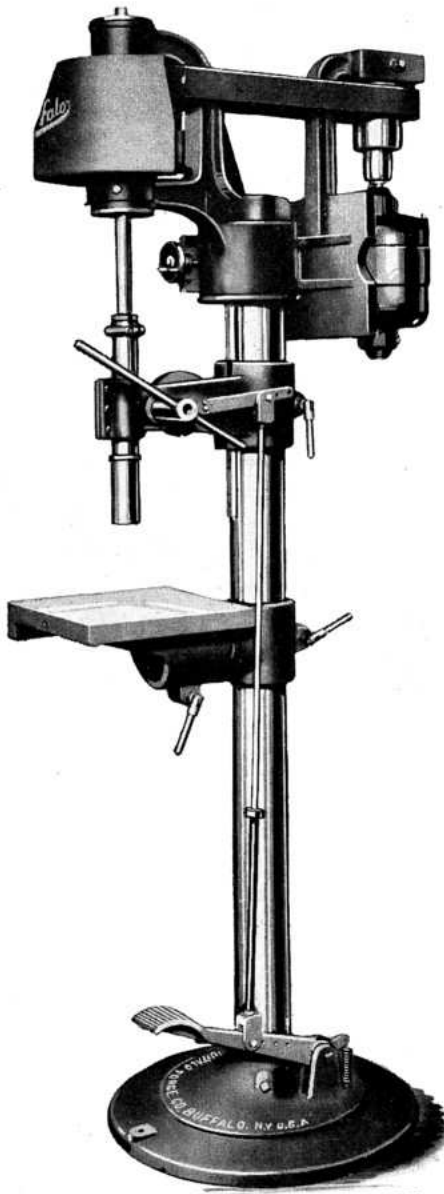

Buffalo 16-inch Floor Drill

Buffalo

Buffalo 15-inch Upright Power Drill

This drill, designed for accurate and efficient work, is of durable construction throughout. The top spindle bearing is bronze lined. The bearing for upper drive shaft is babbitted and split for easy adjustment, while the main spindle bearing is so adjustable (by means of 3 set screws) that wear can be taken up easily.

The frame of the drill is a one-piece casting of first class grey iron, accurately machined, with the column turned, ground and polished.

The drill has four speeds and the lever handle is adjustable from 6 to 12 inches. The gears are machine cut, and guarded, assuring smoothness in operation and safety.

The spindle is made of high grade steel—accurately ground, with graduated sleeve, the end thrust of spindle being taken on ball bearings as shown in illustration.

A round adjustable table is furnished which can be raised or lowered by means of a screw. A tilting table can be furnished if desired.

The drill is equipped with a belt shifter conveniently located for foot operation.

Can be furnished direct connected to motor at extra charge. (See page 30.)

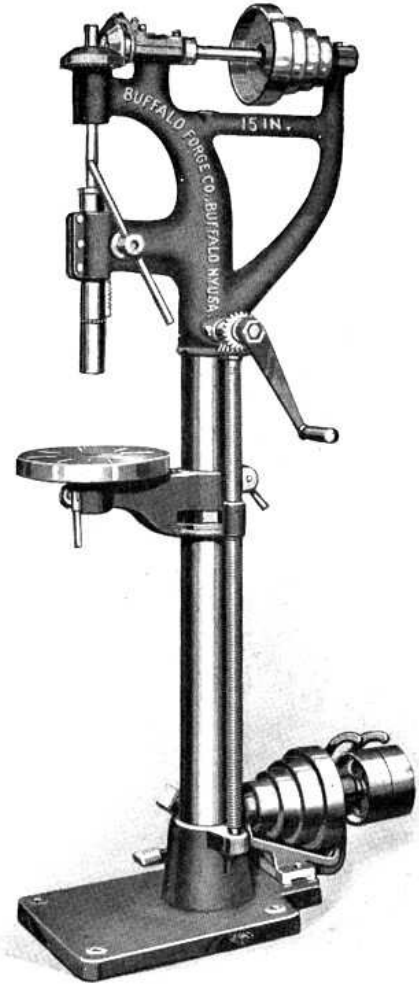

The spindle is held in position by means of a friction spring which automatically keeps the spindle where it is placed.

SPECIFICATIONS

Height of drill 72 in.

Capacity—holes up to $\frac{3}{4}$ in.

Drills to center 15 in. circle

Greatest distance base to spindle 46 in.

Greatest distance table to spindle 33 in.

Travel of spindle 7 in.

Travel of table 29 in.

Diameter of table 12 in.

Size of tight and loose pulleys 6 x $2\frac{1}{8}$ in.

Speed of drive pulleys 225 R.P.M.

Spindle speed, 330, 210, 130, 85.

Smallest diameter of cone pulleys $3\frac{7}{8}$ in.

Largest diameter of cone pulleys 8 in.

Floor space 14 x $32\frac{1}{2}$ in.

Net weight 360 lbs.

Crated weight 450 lbs.

Spindle regularly bored to take No. 2 Morse Taper.

Buffalo

Buffalo 12-inch Hi-Speed Drill

4 Spindle Speeds — 3600,

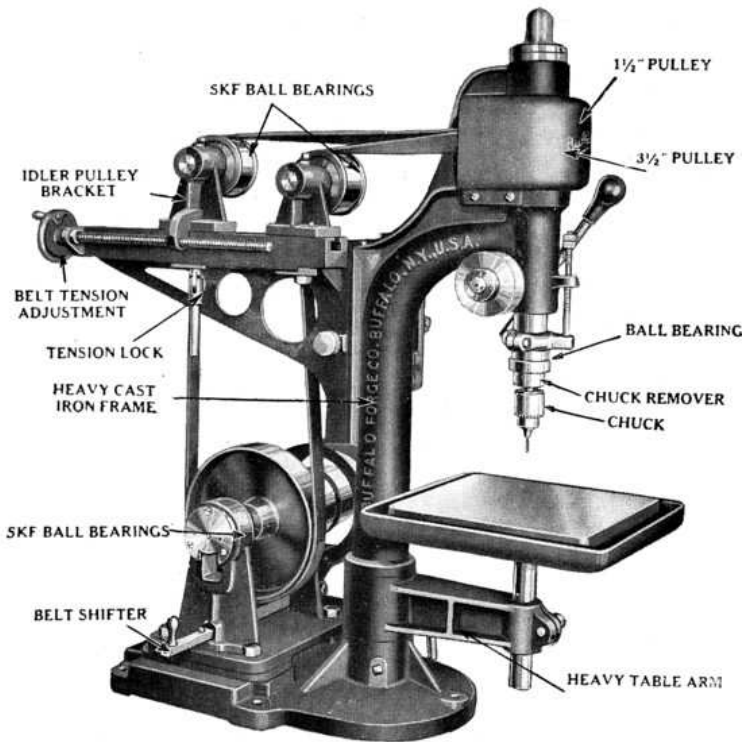

Speedy operation of all parts of the machine is provided by quick acting screws, clamps and levers.

SPECIFICATIONS

- Overall height of drill 34 in.
- Travel of Spindle 3 1/2 in.
- Spindle diameter 1 1/8 in.
- Maximum height of spindle to table 6 1/2 in.
- Speed of drive pulleys 1,800
- Spindle Speeds 10,000, 7,200, 4,800, 3,600 R.P.M.
- Maximum speed recommended 10,000 R.P.M.
- Drills to center of circle 12 in.
- Drills holes up to 5/8 in.
- Power required 1/2 H.P.
- Net weight, pulley drive 220 lbs.
- Crated weight, pulley drive 260 lbs.
- Net weight, motor drive 270 lbs.
- Crated weight, motor drive 310 lbs.
- Equipped with high speed, balanced chuck — capacity up to 1 1/8" which is the largest size recommended for high speeds.

This machine was designed to do a difficult job in the proper way—to stand up under continuous, hard service, to run smoothly and safely and to drill rapidly thru any material that can possibly be drilled. By means of the two upper spindle pulleys and the two lower drive pulleys, four positive spindle speeds, (3,600, 4,800, 7,200 and 10,000 r.p.m.) are provided. Change from one speed to any other of the four is quickly obtained by means of lever and rapid acting screw.

Each drill is tested at 12,000 r.p.m.,

Motor can be furnished for 110 or 220 volt, D.C. or A.C., single or polyphase, 25, 40 or 60 cycle.

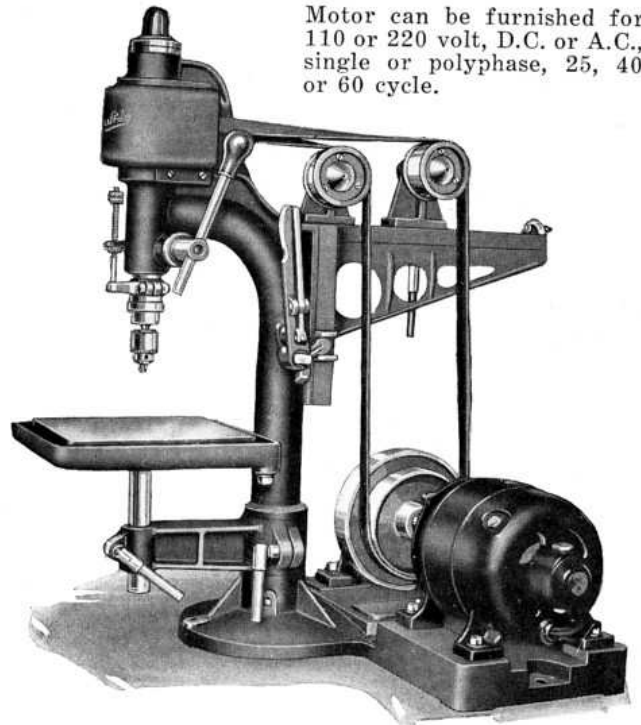

Every part of this drill is exceptionally heavy to stand up under the stresses of high speed operation.

For Motor Drive

This drill can be furnished for direct motor drive by 1/2 H.P. motor, the motor shaft connecting direct to the drive shaft. Except for the extended base, as shown, the details of motor pulley drive are exactly the same. It is necessary to give complete current characteristics when ordering motor drive.

Buffalo

For use on Bench or Floor

4800, 7200 and 10,000 R. P. M.

assuring a positive, dependable margin of safety at its highest operating speed. Eight sets of S.K.F. Ball Bearings, oiled by the Zerk system, provide smooth, trouble-free performance at high speeds.

All parts subject to normal wear are adjustable. Rack and pinion are self adjusting which is very essential to the continuous accuracy of any high speed drill. The oil trough around table has tapped hole for connection to drain tube.



Recirculating pump for cutting compound furnished at extra cost.

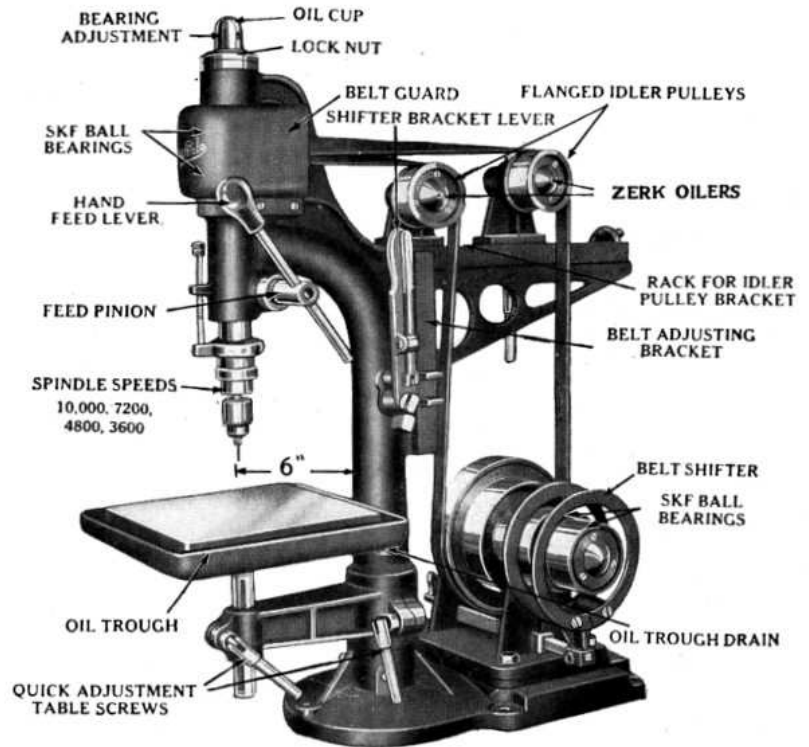

Machine furnished as shown, with belt and high speed balanced chuck.

For Floor Mounting

Both motor and belt driven drills can be equipped with rigid, well balanced pedestals for bolting to floor. The dimensions and weight have been carefully proportioned to afford staple support for the drill at high speeds without carrying excess weight. The pedestal for both motor driven and pulley driven drill are similar except for the removable motor bracket. Can also be furnished with a pump for recirculating the cutting compound. A by-pass valve from pump permits adjustment of the supply at feed nozzle.

SPECIFICATIONS FOR PEDESTALS

Pulley Drive

Weight of pedestal 170 lbs.
 Floor space 14 x 18 1/2 in.
 Total height of drill 68 in.
 Total weight of drill 390 lbs.

Motor Drive

Height and floor space same as for pulley drive.
 Weight of pedestal 205 lbs.
 Total weight of drill 475 lbs.

Buffalo

Arrangements for Motor Drive on Power Drills



Above illustration shows standard motor drive arrangement.

The 25, 24, 21, 20 and 15-inch power drills described and illustrated in the preceding pages are frequently furnished for direct motor drive.

Two methods of mounting motors are illustrated here. At the left is a Buffalo 21-inch power drill with a motor mounted above upper cone pulleys. This method is desirable where floor space is limited or where bulky work is to be handled. This mounting requires an auxiliary bracket, as shown.

If desired we can furnish these drills with motor on a special base, with either gear or silent chain drive as illustrated at right.



The above illustration shows geared motor drive arrangement, which is furnished at an additional charge when desired. Price on application. Complete current characteristics are necessary when ordering.

Tapping Attachments for Buffalo Power Drills

The Buffalo tapping attachment is made for use on the 20, 21, 24 and 25-inch drills.

It is of standard design, accurate, sturdy, well made, and makes a very useful accessory in any shop.

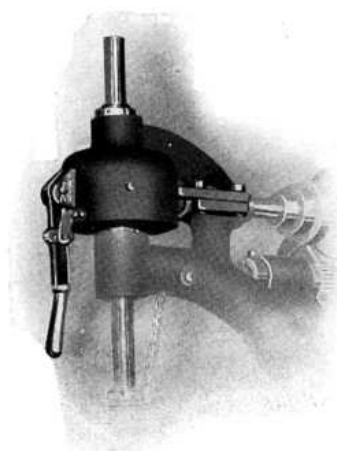

Buffalo

Buffalo 10-inch Three Speed Bench Drill

The Buffalo 10-inch Three Speed Bench Drill is very compact and makes a desirable tool for garages, machine shops, tool rooms, etc. It has a substantial one piece frame, insuring perfect alignment of gears and shafts. The gears are carefully machined and fitted. The upper cone pulley is supported between the bearings instead of being overhung. This type of construction increases the power materially and reduces unnecessary strain on the shaft. Tight and loose pulleys are provided with belt shifter.

The feed lever and spindle are held in position by means of a friction spring which automatically keeps the spindle where it is placed. The work table is adjustable up and down and can be pushed to one side if desired. The base can also be used as a table as it is carefully and accurately planed.



Height of drill 38 in.
Capacity—holes up to $\frac{1}{8}$ in.
Drills to center of 10 in. circle
Greatest distance base to spindle 20 $\frac{1}{2}$ in.
Greatest distance table to spindle 14 $\frac{1}{4}$ in.
Travel of spindle 3 $\frac{5}{8}$ in.
Size of table 7 x 8 in.
Size of tight and loose pulleys 4 x 1 $\frac{5}{8}$ in.
Travel of table 14 in.
Diameter of spindle in sleeve $\frac{11}{16}$ in.
Diameter of column 2 $\frac{1}{2}$ in.

SPECIFICATIONS

Regularly furnished for No. 1 Morse Taper Drill; can also be furnished for No. 2 at an extra charge.
Diameter of crown gear 2 $\frac{7}{8}$ in.
Drill equipped with 3 step cone pulleys
Diameter of large cone 4 $\frac{1}{2}$ in.
Diameter of intermediate cone 3 $\frac{1}{2}$ in.
Diameter of small cone 2 $\frac{1}{2}$ in.
Spindle speed on high 771 R.P.M.
Intermediate, 428 R.P.M.
Low, 305 R.P.M.
Countershaft run 600 R.P.M.
Net weight, 110 lbs.
Crated weight, 120 lbs.



Motor Driven

When direct motor drive is preferred a special set of cone pulleys is fastened to the motor shaft and belted to the upper cone pulleys. This eliminates gear noises, saves space and delivers the full power of the motor to the belt.

The $\frac{1}{4}$ H.P., 1750 R.P.M. motor handles the capacity of this drill.

The specifications of the motor drive are same as above except the weights which are as follows:

Net weight
135 lbs.

Crated weight
150 lbs.

Complete current characteristics are necessary when ordering.

The 10" Power Drill has two cone pulleys, with the following sizes:
Small Cone Pulley Diameter, 2" x 2 $\frac{5}{8}$ " x 3 $\frac{1}{4}$ "; Large Cone Pulley Diameter, 4 $\frac{5}{8}$ " x 5 $\frac{1}{4}$ " x 5 $\frac{7}{8}$ "; Spindle Speed—High 880, Medium 625, Low 435.

Buffalo

Buffalo 10-inch Junior Bench Drill

TWO SPEEDS

The 10-inch Junior Bench Drill is the smallest power drill made by us. It has a substantial one-piece cast-iron frame, assuring rigidity and permanent alignment. The spindle is of steel, accurately finished and running in large bronze bearings. All pulleys are accurately balanced, permitting high speed operation. The adjustable table, 8" in diameter, has a vertical travel of 7" and can be swung entirely out of the way if desired. When ordered No. 2-A Jacobs Chuck will be furnished on pulley driven drill at extra cost.

Not necessary to loosen idler pulley—when shifting speeds, snap socket holds idler in either position—no wrenches needed.

This drill is very popular in radio shops, pattern shops, machine shops, garages, tool rooms, etc., because of its accuracy, light weight and simplicity in handling on holes up to $\frac{3}{8}$ inch.



PULLEY DRIVE

SPECIFICATIONS

Height of drill 27½ in.
Capacity—holes up to $\frac{3}{8}$ in.
Drills to center of 10 in. circle
Greatest distance table to spindle 8 in.
Travel of spindle 3½ in.
Diameter of table 8 in.
Size of tight and loose pulleys 4 x 1½ in.
Vertical movement of spindle 3½ in.
Vertical movement of table 7 in.
Distance center of spindle to frame 5 in.
Speed of driving pulleys 550 R.P.M.
Net weight, pulley driven, 66 lbs.
Crated weight, pulley driven, 78 lbs.
Net weight, motor driven, 100 lbs.
Crated weight, motor driven, 130 lbs.

Motor Driven

The 10-inch Junior Bench Drill described above is also furnished for direct motor drive by connecting $\frac{1}{4}$ H.P. Motor, as shown.

This machine can be made to run 850 R.P.M. low, 1450 R.P.M. high, with the addition of a special cone pulley on spindle at an extra charge.

Spindle fitted with No. 2-A Jacobs chuck.

Complete current characteristics are necessary when ordering.



The spindle speed of the 10" Junior Standard Motor Drive is 1000 R.P.M., slow speed and 2100 R.P.M., fast speed. Furnished complete with chuck, belt and switch—ready for the job.



"Buffalo" 10" Junior Bench Drill mounted on Pedestal. Furnished only when ordered. Extra charge.

Buffalo

Buffalo Ball Bearing Drill No. 124

This drill has a sturdy, cast iron frame mounted on a heavy post. It has two speeds, which can be changed from one to another by means of a sliding collar, located behind the spindle.

Has hand and automatic feeds. The hand feed has four-arm lever while the automatic feed is adjustable. All gears are machine cut and guarded. The capstan lever can be placed at either right or left hand side. A slotted adjustable table is furnished.

Four step cone pulleys and countershaft supplied if desired.

SPECIFICATIONS

Drills to center of 24 in. circle
 Drills holes up to 1½ in.
 Diameter of spindle 1¼ in.
 Run of feed 7½ in.
 Run of table 16½ in.
 Length 68 in.
 Pulley 8 x 3 in.
 Pulley speed 100-125 R.P.M.

Furnished with chuck bored for ½ in. straight shank bits. Can also be bored for 41/64 in. or Nos. 1, 2, 3 or 4 Morse Taper at an extra charge.

124 (Hand Power) net weight 360 lbs.; crated weight, 435 lbs.
 124-A (With Pulleys) net weight 380 lbs.; crated weight, 455 lbs.

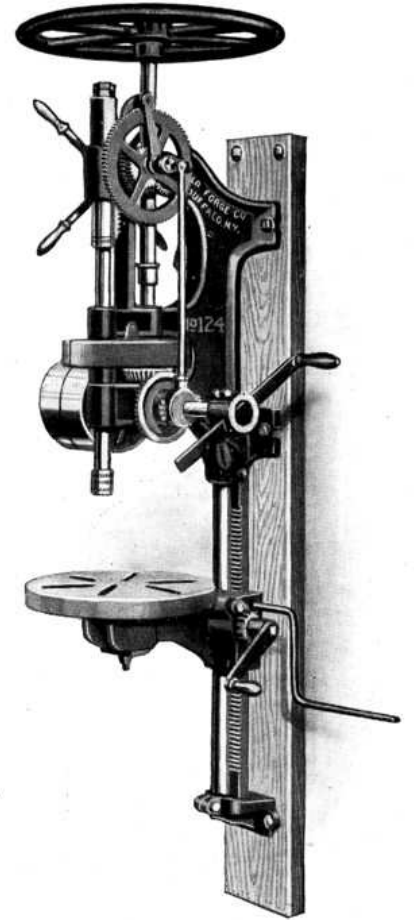

Buffalo Capstan Lever Drill No. 117

This is the smallest capstan lever drill made by us. The frame is heavily ribbed and all bearings bored and reamed in solid metal of frame. A ball bearing takes up thrust between feed rack and spindle and eliminates about 90% of the friction.

It has two speeds which are obtained by shifting crank from front to back gear. An idler between the gears permits crank to be turned forward with both speeds. A sliding collar on feed head gives a quick and simple change from hand to automatic feed. Slotted adjustable table furnished.

SPECIFICATIONS

Drills to center 17 in. circle
 Drills holes up to 1¼ in.
 Spindle diameter 1¼ in.
 Run of feed 6 in.
 Run of table 13 in.
 Length overall 50 in.
 Pulley size 8 x 3 in.

Furnished with chuck for ½ in. straight shank bits. Can also be had for 41/64 in. and Nos. 1, 2 or 3 Morse Taper at an extra charge.

No. 117 (Hand Power) net weight, 143 lbs.; crated weight, 175 lbs.
 No. 117A (With Pulley) net weight, 163 lbs.; crated weight, 195 lbs.

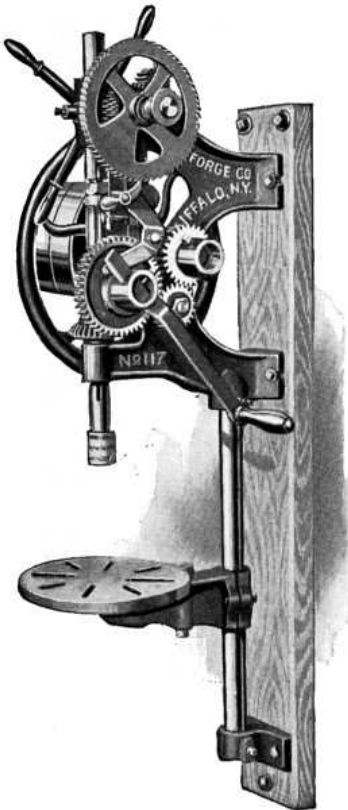

Buffalo

Buffalo Ball Bearing Drill No. 515

This drill has a heavy cast iron frame, mounted on a large hardwood post and will stand up under continuous hard service. All bearings are bored and reamed in solid metal frame. It has two speeds which are obtained by changing crank from front to back gear.

A quick change from lever to automatic feed or vice versa is easily obtained at the feed screw head. The spindle can be returned to the highest point of travel instantly. Cast gears mesh perfectly. A square slotted adjustable table furnished.

SPECIFICATIONS

Drills to center of 15 in. circle
Drills holes up to $1\frac{1}{4}$ in.
Spindle diameter $1\frac{1}{8}$ in.
Run of feed 3 in.
Run of table $9\frac{1}{2}$ in.
Length overall 38 in.
Pulley diameter 6 in.

Furnished with chuck for $\frac{1}{2}$ inch straight shank bits.
Can also be furnished for $\frac{5}{8}$, $\frac{41}{64}$ in. or Nos. 1, 2, or 3 Morse Taper at an extra charge.
No. 515 (Hand Power) net weight, 120 lbs. Crated weight, 160 lbs.
No. 515-A (With Pulleys) net weight 140 lbs. Crated weight, 180 lbs.

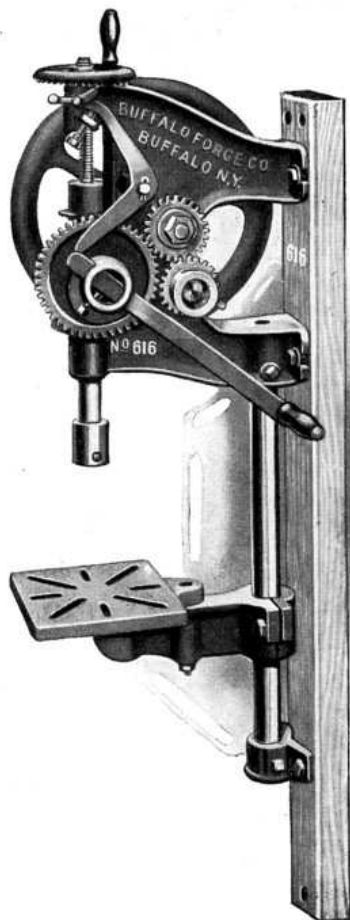
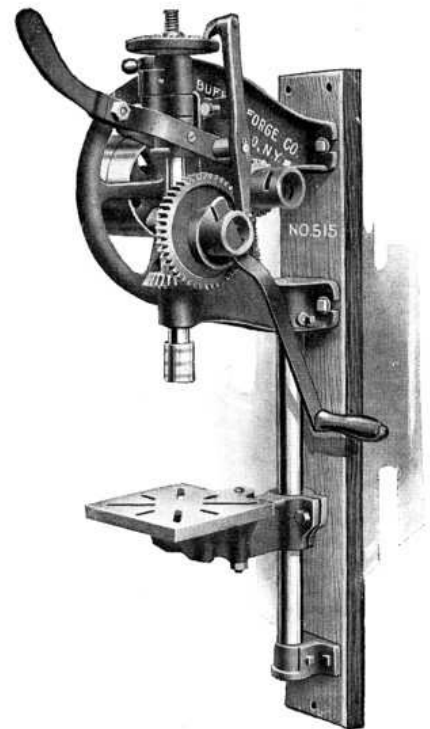

Buffalo Ball Bearing Drill No. 616

The shafts and spindle of this drill are steel, machined and fitted, with all bearings bored and reamed in solid metal of frame. It has two speeds and is back-gearred. A quick change from one to another is easily obtained by shifting the crank from front to rear gear or return.

Two feeds, hand and automatic, are provided. A small adjusting screw at feed screw head allows automatic feed to be adjustable to three speeds. The end thrust is taken up by hardened steel balls between feed screw and spindle, reducing considerable friction.

A square slotted adjustable table is supplied. Can be furnished with or without loose pulley.

SPECIFICATIONS

Drills to center 16 in. circle
Drills holes up to $1\frac{1}{4}$ in.
Spindle diameter $1\frac{1}{8}$ in.
Run of feed $3\frac{1}{4}$ in.
Run of table 10 in.
Length overall 38 in.
Diameter of pulley 6 in.

Furnished with chuck for $\frac{1}{2}$ in. straight shank bits. Can also be bored for $\frac{41}{64}$ in. or Nos. 1, 2, or 3 Morse Taper at an extra charge.
No. 616 (Hand Power) net weight, 98 lbs. Crated weight, 115 lbs.
No. 616-A (With Pulleys) net weight, 110 lbs. Crated weight, 127 lbs.

Buffalo

Buffalo Ball Bearing Drill No. 614-R

This machine has a strongly ribbed cast iron frame mounted on a substantial post. The shaft and spindle are of steel, finely finished and carefully fitted.

Both hand and automatic feeds are provided—the latter being adjustable to three speeds. It has one spindle speed. A hardened steel ball bearing takes up friction between spindle and feed screw. An adjustable, slotted table is furnished. Fitted regularly with a $\frac{1}{2}$ inch straight shank drill.

SPECIFICATIONS

Drills to center of 14-inch circle
Drills holes up to $1\frac{1}{4}$ inches
Spindle diameter 1 inch
Run of feed 3 inches
Run of table $10\frac{1}{4}$ inches
Length overall 38 inches

Furnished with chuck for $\frac{1}{2}$ inch straight shank bits.
Can also be bored for $\frac{41}{64}$ inch or Nos. 1, 2 or 3 Morse Taper at an extra charge.
Net weight, 83 lbs.
Crated weight, 98 lbs.

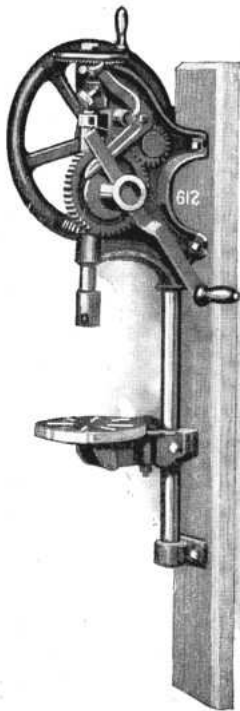
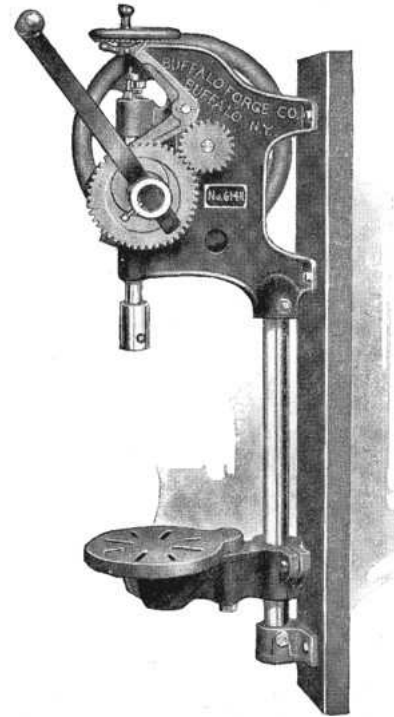

Buffalo Ball Bearing Drill No. 612

This drill is a good substantial machine built to stand up under continuous, hard usage. It has a sturdy cast iron frame, with a steel shaft and spindle, accurately machined, fitted and finished. All bearings are bored and reamed in the solid metal frame.

Two feeds, hand and automatic, are provided; the latter being adjustable to three speeds. A round, slotted table is furnished. Fitted with chuck for $\frac{1}{2}$ " straight shank bits.

SPECIFICATIONS

Drills to center 12 inch circle
Drills holes up to 1 inch
Spindle diameter $1\frac{1}{8}$ inches
Run of table 10 inches.
Run of feed $2\frac{3}{4}$ inches
Length overall 35 inches

Furnished with chuck for $\frac{1}{2}$ inch straight shank bits. Can also be bored for $\frac{41}{64}$ inch or Nos. 1, 2 or 3 Morse Taper at an extra charge.
No. 612 (Hand Power) net weight, 71 lbs. Crated weight, 86 lbs.

Buffalo

Buffalo Ball Bearing Drill No. 611-R

The frame of this machine is strongly ribbed, with steel shaft and spindle, carefully fitted and finely finished. The end thrust of spindle is taken up by ball bearings, eliminating 90% of all the friction at this point. All the bearings are bored and reamed in the solid metal of frame. The gears are well made and carefully fitted. Has both hand and automatic feeds—the latter being adjustable to three speeds. A round, slotted, adjustable table is provided. Fitted regularly with a Buffalo chuck.

SPECIFICATIONS

Drills to center of 11 inch circle
 Drills holes up to $\frac{3}{4}$ inch
 Spindle diameter $\frac{7}{8}$ inch
 Run of feed 3 inches
 Run of table 10 inches
 Length overall 33 inches

Furnished with chuck for $\frac{1}{2}$ inch straight shank bits. Can also be bored for $\frac{41}{64}$ or No. 1 or 2 Morse Taper at an extra charge.
 Net weight, 68 lbs.
 Crated weight, 75 lbs.

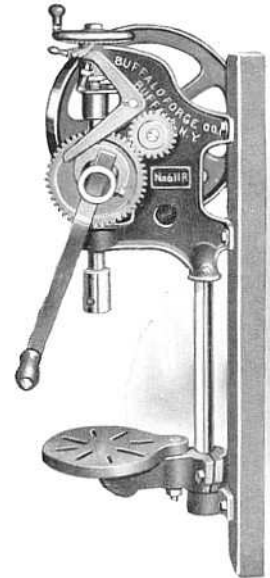

Buffalo Ball Bearing Drill No. 61-R and 65-R

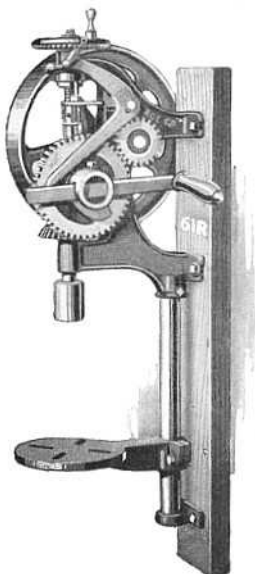

No. 61-R—A sturdy, well made machine that is very useful in every shop. It has a cast iron frame with all bearings being bored and reamed, assuring smooth, easy running. The shaft and spindle are of steel, extra heavy and carefully finished. Accurately fitted gears and a medium weight flywheel aid in simplicity of the operation. Has a combination cast iron table and fork, which is adjustable to any position.

No. 65-R—Similar to 61-R except it has two speeds, a sheet steel table and cast iron fork. This permits table to be taken off and enables rims of wheels, etc., to be drilled on fork. It cannot, however, be furnished with pulleys unless the handle is taken off.

The end thrust of both of these drills is taken up by ball bearings, eliminating 90% of all the friction at this point.

SPECIFICATIONS

Drills to center of $11\frac{1}{2}$ inch circle
 Drills holes up to $\frac{5}{8}$ inch
 Spindle diameter, $\frac{7}{8}$ inch
 Run of feed, 3 inches
 Run of table, 9 inches
 Length overall 32 inches
 Size of pulleys (61-A) $6 \times 2\frac{1}{4}$ inches

Spindle bored for $\frac{1}{2}$ inch straight shank bits. Can be bored also for $\frac{41}{64}$ inch, $\frac{5}{8}$ inch or Nos. 1 or 2 Morse Tapers at an extra charge.

Drill No.	Net Weight	Crated Weight
61-R (Hand Power)	55 lbs.	63 lbs.
61-A (Hand & Power)	60 lbs.	68 lbs.
65-R (Hand Power)	53 lbs.	61 lbs.

Buffalo

Buffalo Hand Power Punches, Shears, Bar Cutters and Benders

THE portable hand-power punches, shears and bar-cutters shown in this section are built to meet every shop requirement for punching and cutting metal. They combine "Armor-Plate", guaranteed unbreakable, all-steel frames with inherent light weight, and compounded leverage that makes cutting and punching to the full capacity of the machine easy and positive. Clean holes and cuts are certain.

Buffalo machines occupy very little floor space and weigh far less than cast-iron machines of similar capacity—but are more than seven times as strong.

Modern production methods enable us to sell these machines at a very reasonable price, assuring the user of exceptional value.

Buffalo

Buffalo Open Throat Combination Angle and Tee Cutter

The big feature about this machine is its open throat. This permits the entering of material from the front of the machine instead of inserting it through the sides, as is the case with most angle cutters. This feature reduces wear and tear on the knives, consequently prolonging their life, and also makes it possible to do the work in much less space than with machines where the material is run in from the side, over the knives. Saves considerable time, material and labor.

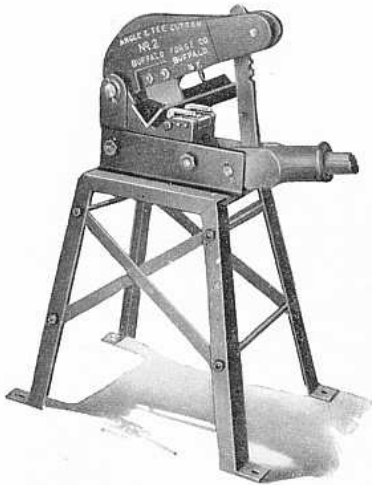

These machines are mounted on the special Buffalo 2-piece angle iron legs which are very rigid, and light. Drilled for bolting to the floor.

Each machine tested in excess of capacity. Can be furnished as illustrated or for bench use only.

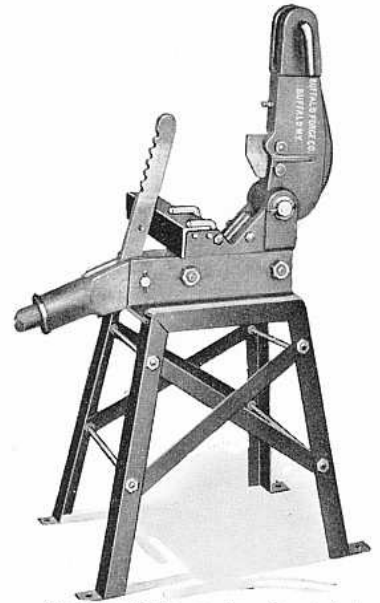

By use of the pawl and ratchet a much greater leverage is obtained, thereby making it possible to punch and shear heavy stock with little effort.

No.	Angles	CUTS			Punches Holes	Net Weight	Crated Weight
		Tees	Flats				
1	1 3/4 x 1 3/4 x 3/16"	1 1/4 x 1 1/4 x 3/16"	1 1/4 x 3/8"	1/2 x 3/16"	113 lbs.	118 lbs.	
2	2 1/2 x 2 1/2 x 1/4"	1 3/4 x 1 3/4 x 3/16"	1 3/4 x 1/2"	1/2 x 3/16"	175 lbs.	180 lbs.	
3	3 x 3 x 3/8"	2 1/4 x 2 1/4 x 1/4"	2 1/2 x 1/8"	5/8 x 3/8"	440 lbs.	448 lbs.	

Angle Knives are Standard equipment—Tee Knives furnished at extra cost. Punching attachment also extra.

Buffalo Angle and Tee Bender

Buffalo No. 2 Angle and Tee Bender will bend angles up to 2 1/2 x 2 1/2 x 1/4" and tees up to 2 1/2 x 2 1/2 x 1/4". A sturdy, cast-iron frame, together with two steel forming blocks and steel lever assures accuracy in bending and makes it possible to bend squares as small as 8" on the inside. A very handy tool for structural work in connection with our power machines.

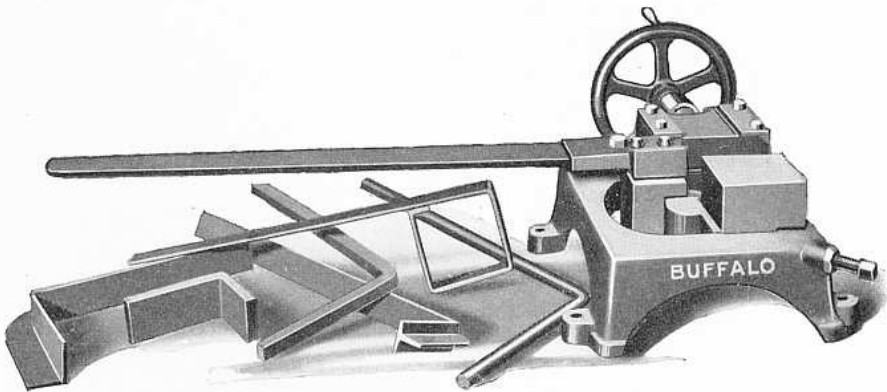

The same blocks can be used for bending both angles and tees.

Bends tees, leg in or out, up to 2 1/2 x 2 1/2 x 1/4".

Bends Angles, leg in or out, up to 2 1/2 x 2 1/2 x 1/4".

Bends Flats up to 3" x 1".

Bends Rounds up to 1 1/2".

Bends Squares up to 1 1/4".

Width 22", length 30", Shipping weight 400 lbs.

All stock must be heated to a cherry red.

"Buffalo"

Buffalo "Armor-Plate" Combination Punch Shear and Bar-Cutter

This double end machine meets the requirements of three machines, a slitting shear, a punch and a barcutter. The frame, made of "Armor Plate" steel is guaranteed forever against breaking under any conditions. The leverage, although simple, is very powerful and has no parts to get out of order. Heavy angle iron legs are supplied.

The offset in the frame prevents the stock from binding when shearing plates, and guides the plate accurately along a straight line. Punches and dies are of the best crucible steel, carefully ground and tempered.

This machine regularly furnished with $\frac{1}{4}$ ", $\frac{5}{16}$ " and $\frac{3}{8}$ " punches with dies to fit.

No.	Punches	SHEARS			Throat	Net Weight	Crated Weight
		Plates	Rounds	Flats			
22SP	$\frac{3}{8}$ x $\frac{1}{4}$ "	$\frac{1}{4}$ "	$\frac{5}{8}$ "	$2\frac{1}{2}$ x $\frac{5}{16}$ "	4"	215 lbs.	235 lbs.

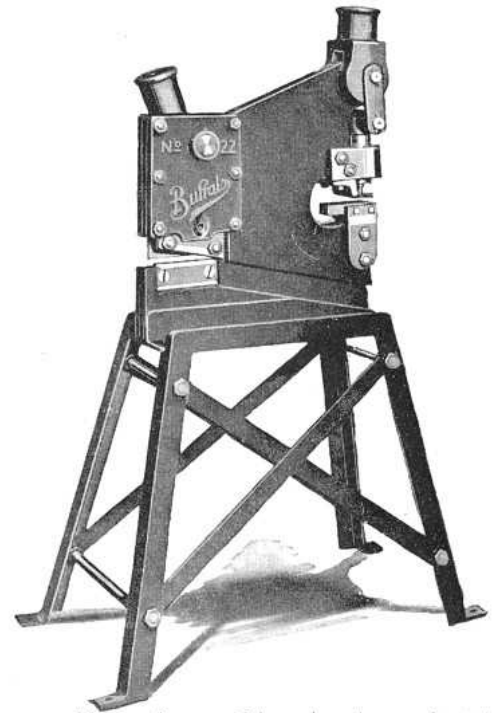

Plates of any width or length may be cut on this machine as well as rounds and flats.

Buffalo Bench Type Slitting Shears

Buffalo No. 14 Slitting Shear, the smallest hand power unit made by us, is 6 inches long and $5\frac{1}{4}$ inches high (without handle). The frame is a high grade drop forging and leverage is so powerfully compounded that it will cut 16 gauge sheets, taking $1\frac{3}{4}$ inch cut per stroke. This powerful little tool will also shear $\frac{3}{4}$ x $\frac{1}{8}$ " flats in a single stroke. Occupies little space and will more than pay for itself in a very short time. Shipping weight 20 lbs.

Both Shears are very handy for shops where considerable strand or solid wire is cut. The No. 14 Shear will cut wire up to No. O, while the 19-A will cut No. OOOO wire and No. 14 BX Cable.



No. 14 Shear. A strong, efficient shear that occupies very little bench space.

The No. 19A Shear is a very useful bench tool for any shop where quantities of sheets, flats and rounds are cut. It has a cast steel frame and plunger guide, and a powerfully compounded leverage by means of steel lever and rack and pinion. A stripper outside prevents binding of metal and a slotted base permits shear to be bolted to table. Will stand unusually hard and continuous service.

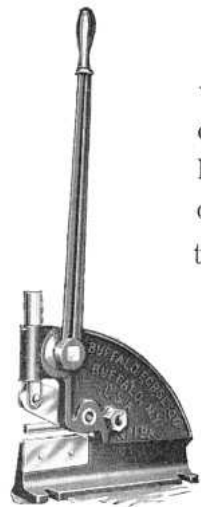

No. 19A Shear

Shears and Slits #12 gauge sheets.

Cuts Rounds $\frac{7}{16}$ ".

Length of Knives $4\text{-}\frac{3}{16}$ ".

Cuts Flats $\frac{3}{4}$ x $\frac{1}{4}$ ".

Shipping Weight 40 lbs.

Buffalo

Buffalo "Armor-Plate" Slitting Shears

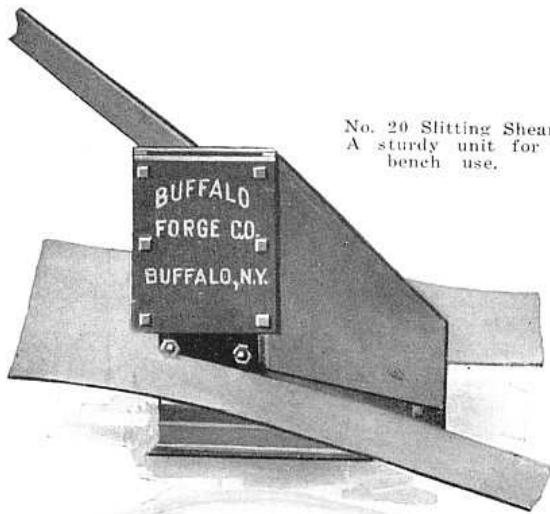

No. 20 Slitting Shear.
A sturdy unit for
bench use.

The working parts are steel and cut the metal absolutely straight and clean.

The No. 23 Slitting Shear is one of the most powerful hand operated machines being used today. It has two levers, one direct acting for light work, the other one giving a compound leverage for heavy work by means of a ratchet keyed to the axis and operated by a lever and pawl. Though light in weight, this machine is guaranteed to stand up under the most severe service.



No. 23 Slitting Shear. Can also be furnished without stand.

Buffalo No. 20 Slitting Shear has an "Armor Plate" frame, guaranteed for life against breakage. The knives are made of crucible steel. The leverage is so compounded that cuts up to the full capacity are made with little effort. The plunger is actuated by an eccentric and moves in machined guide.

The No. 22 Slitting Shear is a larger, more powerful machine, mounted on extra heavy angle iron legs. The knife plunger is operated by an eccentric, working on the principle of a power punch. The offset in the frame prevents binding of the metal when cutting.

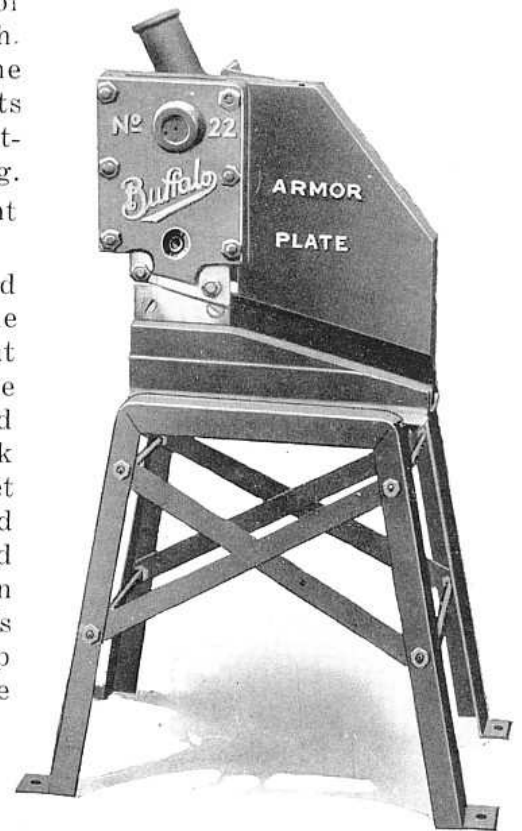

No. 22 Slitting Shear can cut sheets of any length or width. Cuts rounds up to $\frac{5}{8}$ inch. Can also be furnished without stand.

No.	Type	CUTS			Net Weight	Crated Weight
		Rounds	Plates	Flats		
20	Bench	$\frac{1}{8}$ " thick	$2\frac{1}{2} \times \frac{1}{8}$ "	30 lbs.	35 lbs.
20C	Legs	$\frac{1}{8}$ " thick	$2\frac{1}{2} \times \frac{1}{8}$ "	65 lbs.	70 lbs.
22	Legs	$\frac{5}{8}$ "	$\frac{1}{4}$ " thick	$2\frac{1}{2} \times \frac{5}{16}$ "	110 lbs.	115 lbs.
23	Legs	$3\frac{3}{8}$ "	$\frac{3}{8}$ " thick	$2\frac{1}{2} \times \frac{1}{2}$ "	250 lbs.	260 lbs.

With special knives, No. 23 also cuts Angles up to $1\frac{1}{2}$ " x $\frac{1}{4}$ " and Squares up to $\frac{3}{4}$ ".

Buffalo

Buffalo "Armor-Plate" Combination Punch and Shears

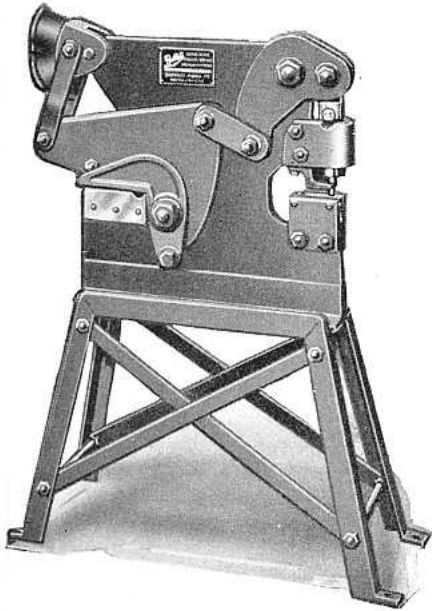

Twin socket lever operates both punch and shear on Nos. 103-B and 104-B machines.

These three machines, the most popular hand power combination machines made by us, have "Armor-Plate" frames, which have a tensile strength of 75,000 pounds (over seven times stronger than cast-iron).

The leverage is simple and powerful. The knives, punches and dies are of the best quality crucible steel, carefully ground and tempered. The punches and shears on these machines do clean, accurate work up to their full capacities. Extra heavy angle iron stand furnished.

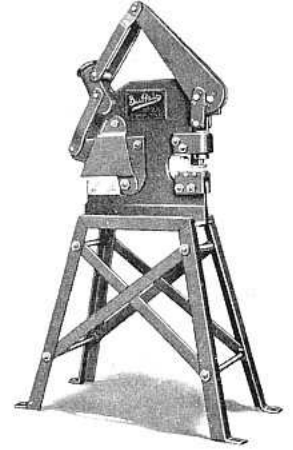

No. 2B Punch and Shear with compounded leverage.

No.	Punches	Flats	Punches Furnished	Throats	Net Weight	Crated Weight
2B	1/4 x 1/4"	2 x 1/8"	1/8, 3/16, 1/4"	3 3/4"	120 lbs.	128 lbs.
103B	3/8 x 3/8"	2 1/2 x 1/2"	1/4, 3/16, 3/8"	4"	200 lbs.	212 lbs.
104B	1/2 x 1/2"	3 x 5/8"	1/4, 3/8, 1/2"	5 1/4"	362 lbs.	380 lbs.

Buffalo "Armor-Plate" Punches

Buffalo Punches Nos. 13 and 14 are particularly suitable on a one-man job. They are simple to operate and the leverage on both is so arranged that punching up to the machines full capacity is easily handled. Regularly furnished with extra heavy angle iron legs.

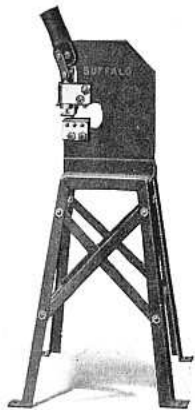

No. 14 Punch. A strong, efficient machine that occupies very little floor space.

No.	Punches	Depth of Throat	Type Lever	Punches Furnished	Net Weight	Crated Weight
13	1/4 x 1/4"	4"	Front	1/8 & 1/4"	75 lbs.	80 lbs.
14	3/8 x 3/8"	4 1/4"	Front	1/8 & 3/8"	104 lbs.	110 lbs.

Buffalo Punch No. 115B is similar to Nos. 13 and 14 except it has a back lever instead of the front lever, a necessary arrangement when working large plates.

No.	Capacity up to	Throat	Punches	Net weight	Crated weight
115B	1/2 x 1/2"	5 1/4"	1/4, 3/8, 1/2"	225 lbs.	260 lbs.

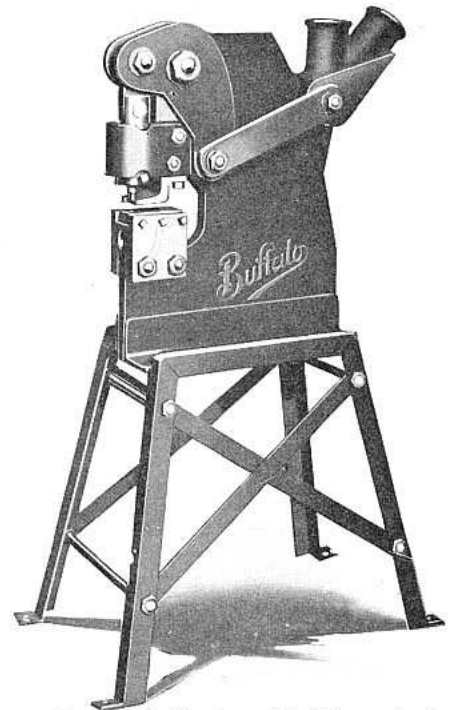

No. 115-B Punch. All fittings steel and accurately machined.

Buffalo

Buffalo "Armor-Plate" Shears

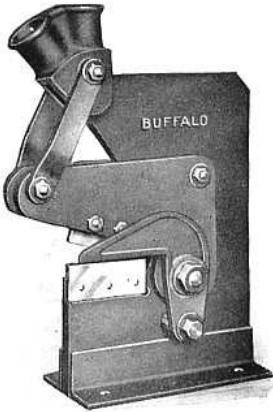

Buffalo Shear No. 104. A strong, indestructible unit that will last a life time.

If you do erecting work of any kind, where quantities of flats and rounds must be cut, you will find the Buffalo "Armor-Plate" Shears Nos. 103 and 104 just the machines you are looking for. The leverage is powerfully compounded. A stripper on the side prevents binding. Made to stand exceptionally hard abuse.

No.	Mounted on	Cuts Flats up to
103	Bench	2 1/2 x 1/2 "
103C	Angle Iron Stand	2 1/2 x 1/2 "
104	Bench	3 x 5/8 "
104C	Angle Iron Stand	3 x 5/8 "

Cuts Rounds (with Special Knives)	Net Weight	Crated Weight
3/4 "	112 lbs.	120 lbs.
3/4 "	138 lbs.	146 lbs.
1 "	203 lbs.	212 lbs.
1 "	232 lbs.	242 lbs.

Knives for cutting rounds are extra.

Buffalo "Armor-Plate" Punch, Shear and Bar-Cutter

A very powerful hand operated punch, shear and barcutter. The frame is of "Armor-Plate," over seven times stronger than cast-iron, and strengthened below the die with reenforcing plates, welded to both sides of the frame. The shear blades, punch and die are of a crucible steel. A double socket lever admits of the most efficient application of power, the back brace preventing the possibility of up-ending. Heavy angle irons form a rigid base.

Can be furnished with or without truck.

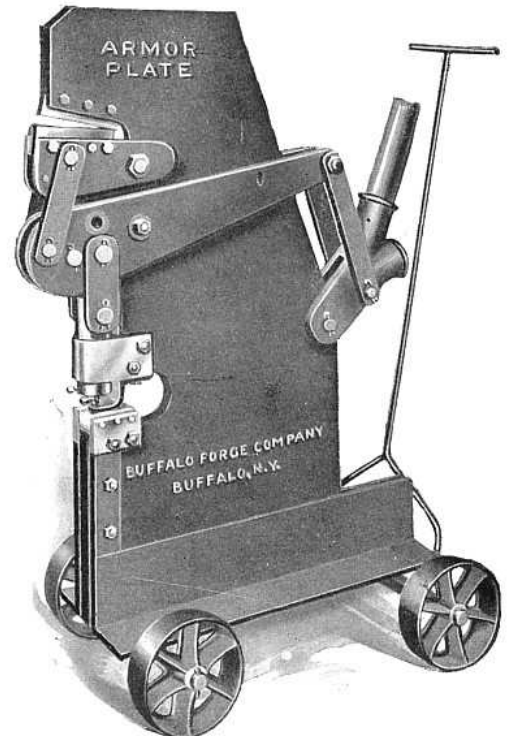

Will cut bars to maximum capacity with comparative ease.

No.	Punches	Cuts Flats	Cuts Rounds	Punches Furnished	Depth of Throat	Shipping Weight
5	3/4 x 1/2 "	6 x 1/2 "	1"	3/8, 1/2, 5/8, 3/4 "	7"	780 lbs.
*5	3/4 x 1/2 "	6 x 1/2 "	1"	3/8, 1/2, 5/8, 3/4 "	7"	860 lbs.

*on truck

Buffalo

Buffalo "Armor-Plate" Contractor's Bar-Cutter

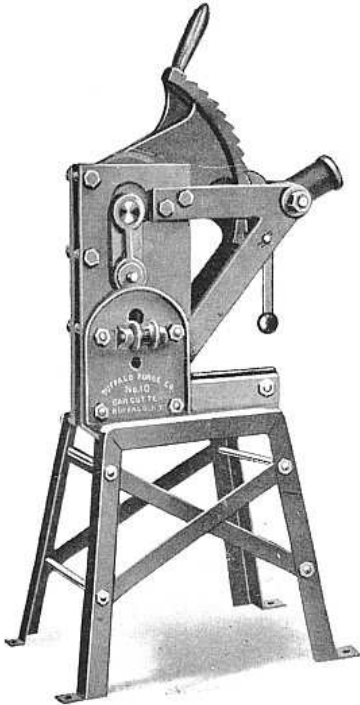

Can be mounted on wheels or furnished without legs for bench use.

The frames of these machines are made of the light but guaranteed unbreakable "Armor Plate" steel, rigidly bolted together, enclosing the working parts. Two sets of knives are provided for cutting light, medium and heavy bars. A stripper prevents binding of the metal. A handle provides for dropping the segment back into place after each cutting.

These machines are regularly equipped with sturdy, angle iron legs which are drilled for bolting down.

No.	Type	Cuts Twisted Squares	Cuts Rounds up to	Net Weight	Crated Weight
10	Angle iron legs	up to 1"	1 1/8"	294 lbs.	305 lbs.
10-A	Wheels attached to legs	up to 1"	1 1/8"	319 lbs.	319 lbs.
10-B	Without Legs	up to 1"	1 1/8"	265 lbs.	265 lbs.
11	Angle iron legs	up to 1 1/4"	1 3/8"	478 lbs.	498 lbs.
11-A	Wheels attached to legs	up to 1 1/4"	1 3/8"	503 lbs.	503 lbs.
11-B	Without legs	up to 1 1/4"	1 3/8"	439 lbs.	439 lbs.

Buffalo "Armor-Plate" Coping Machine

This machine was purposely designed for coping. It is well built with "Armor-Plate" steel frame, angle iron base welded to the frame plate and mounted on an angle iron stand. The steel lever and links, crucible steel punch, dies and coping tools will stand up under the most severe service.

The coping tools, used for notching angles, are interchangeable with punching tools of a capacity up to 1/2-inch hole in 1/2-inch stock. Regularly equipped for coping only. Punching attachment supplied at a small extra cost.

Capacity: Notches up to 90°; in angles up to 2 1/2 x 2 1/2 x 1 1/4"; depth of throat, 5 1/4"; net weight, 250 lbs.; crated weight, 260 lbs.

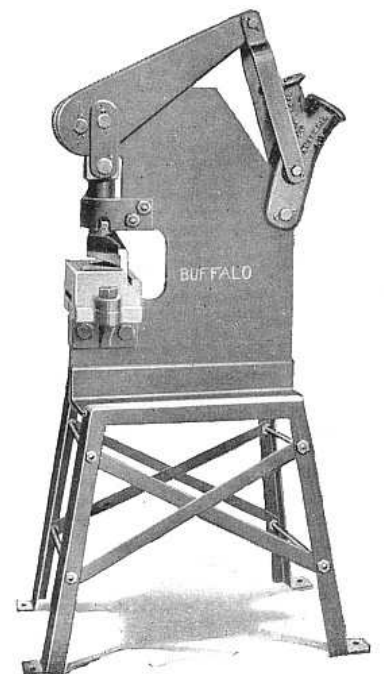

All parts subject to strain and wear are of high strength rolled steel.

Buffalo

Buffalo "Armor-Plate" Universal Iron Workers

If your work involves the cutting of rounds, squares, angles, tees, beams or channels—punching holes in flats, plates, or structural shapes or shearing flats or slitting plates, you will find in the Buffalo Universal Iron Worker a very profitable investment. This machine not only combines several machines in one; punch, barcutter and shear, but it requires no special tools and saves an appreciable amount of set-up time. The frame is made of the well known "Armor-Plate" steel, which has a life guarantee against breakage.

A diagonal plunger enables mitering on a horizontal plane. The eccentric is high carbon steel forging, the flywheel shaft and pinion are nickel steel, with steel gear. Flywheel is keyed to the pinion. The two shear blades have four cutting edges each, and are interchangeable. With only one extra blade you are always ready for an emergency.

Five piece barcutter knives make sharpening and replacement easy and inexpensive. Besides the regular knives, we can furnish special barcutter knives. Gibs are provided in both plungers for taking up wear. Oiling and greasing have been simplified. One of the outstanding features of this machine is that no tools are required for adjusting strippers. Triple punching attachment can be furnished with this machine.

Buffalo Universal Iron Workers are made in three sizes for either pulley or motor drive. Let us know the kind of work you do and we'll show you how much one of these all around machines can save for you.

Complete information on these and other Buffalo power punches, shears and bar cutters is contained in our Punch and Shear Catalog, which will be sent to you on request.

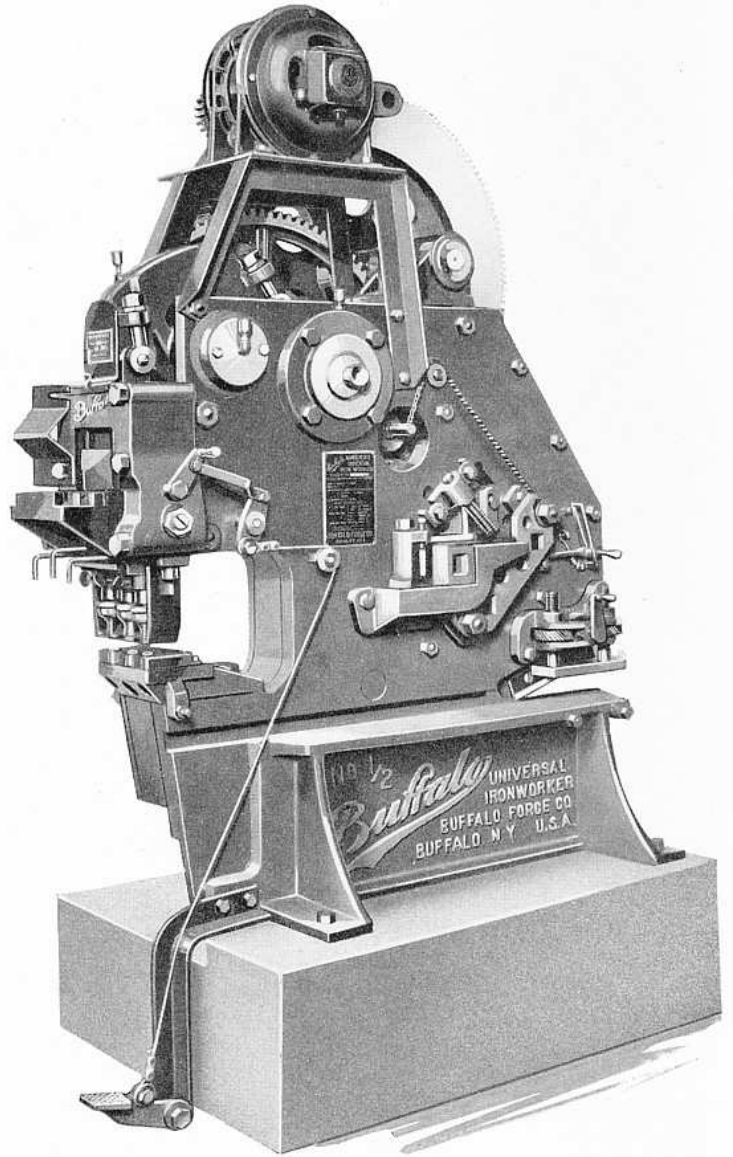

"Buffalo" No. $\frac{1}{2}$ Universal Iron Worker completely equipped with motor and notcher.

Buffalo

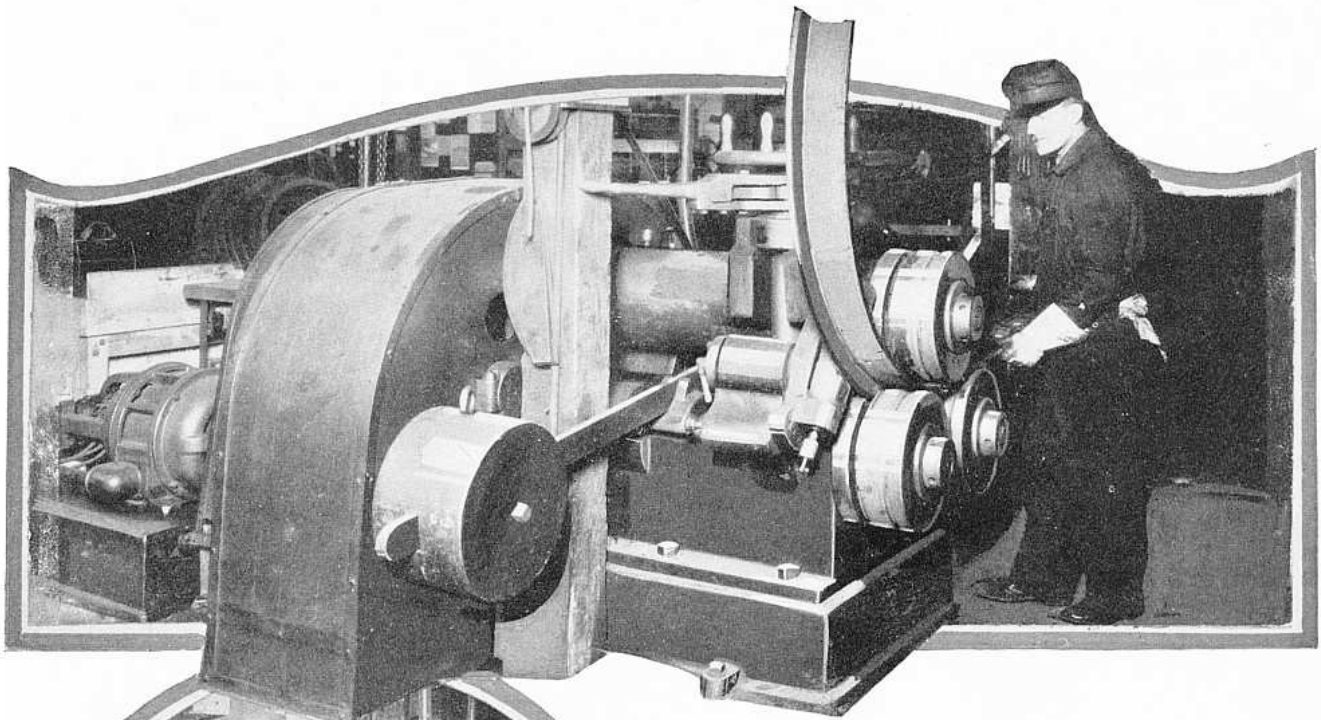

The material being handled in this Buffalo Vertical Bending Roll is 4" x 5" structural steel angle, ½" thick and 12' 5" long.

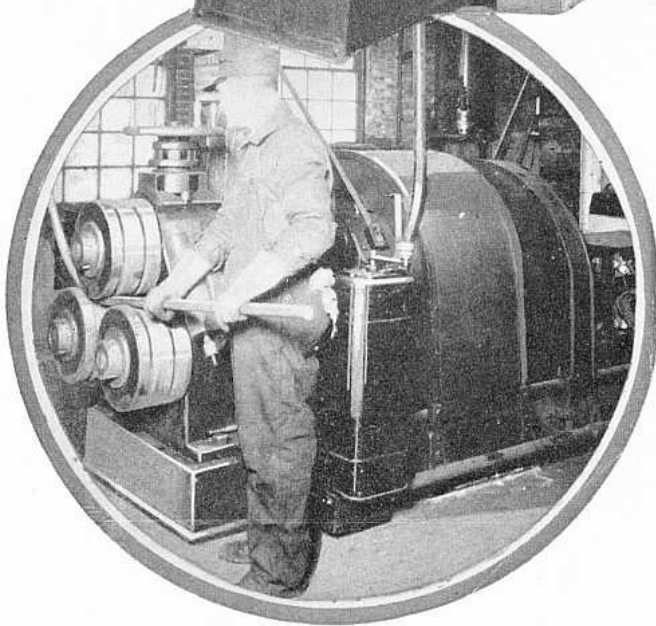

Buffalo Bending Rolls

Hundreds of satisfied owners are unanimous in declaring "Buffalo" Bending Rolls, both horizontal and vertical types, unparalleled for the bending of flats, squares, angles, tees, channels, beams, copper tubes and steel tubes into arcs, circles or spirals. No heating is necessary. Adjustable and interchangeable rolls make one machine meet an unusually wide range of requirements. Combination rolls can be furnished to handle several sizes of flats on edge, rounds or tubes. Special rolls can be built for odd shapes. Made in a variety of sizes.

The horizontal type is suggested for shops where circles of large diameter are bent, as the work is done in a horizontal plane and easier to handle. They will stand up under continuous, hard service.

Regardless of what your product may be, if it involves bending of any kind, we will gladly specify the type, size and style Buffalo Bending Roll that will save you time, money and material.

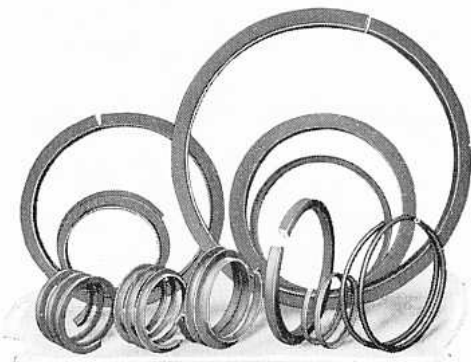

Samples of work done on a Buffalo Bending Roll.

"Buffalo"

Other Buffalo Metal Working Machines

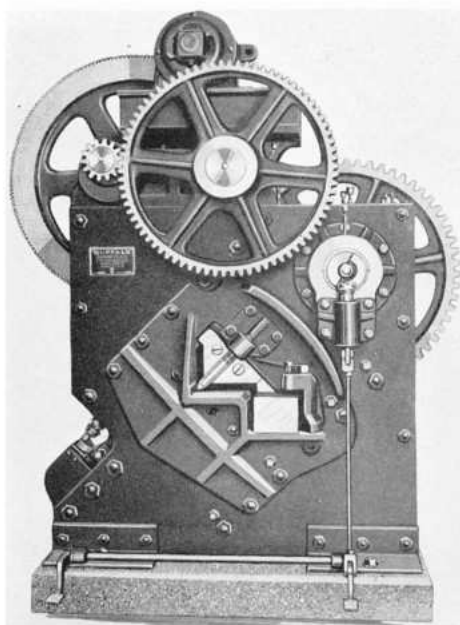

Angle Shear and Punch.

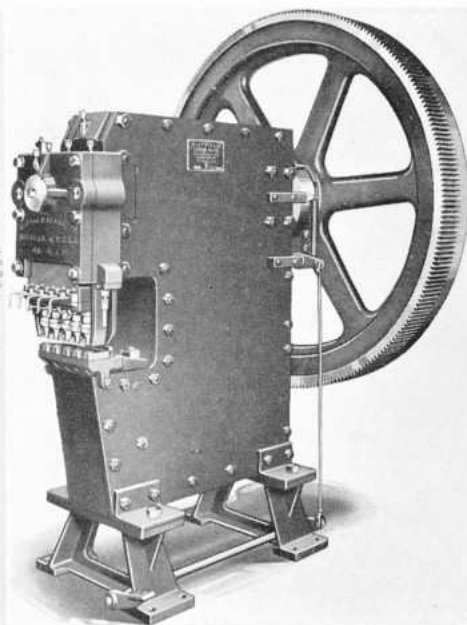

No. 45 Rapid Acting Punch
with multiple head.

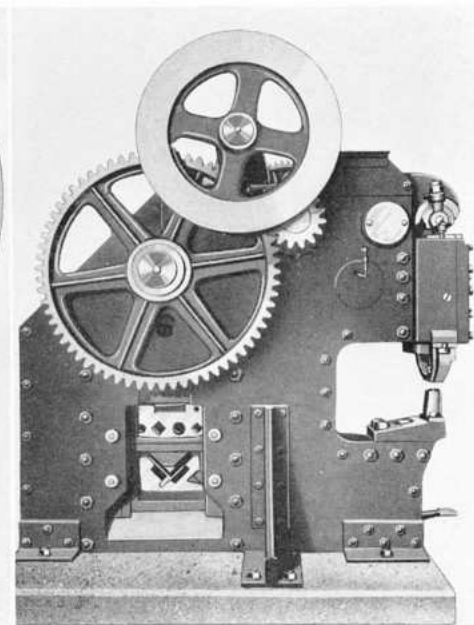

No. 50 Punch and Barcutter.

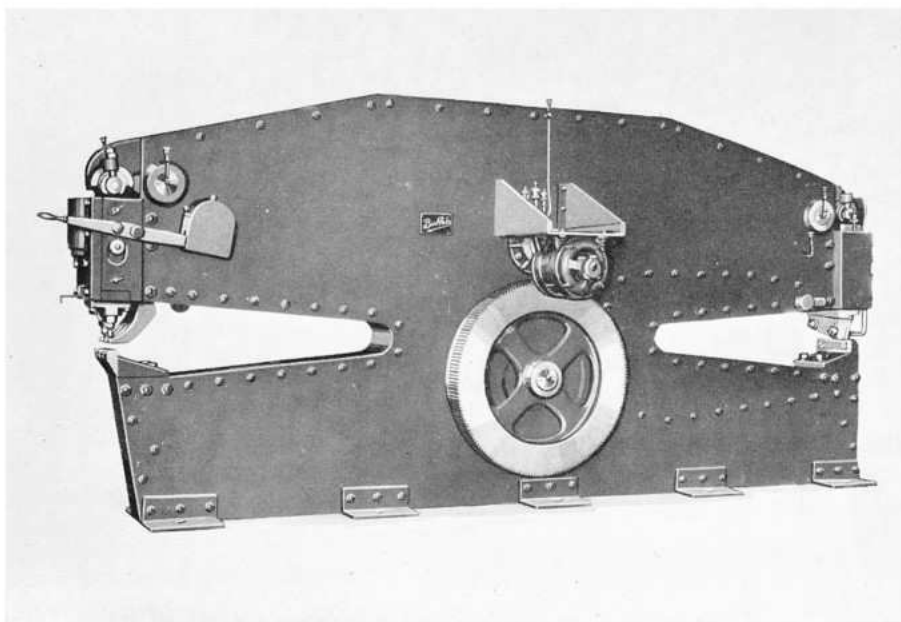

No. 48 x 60 Punch and Shear with motor drive.

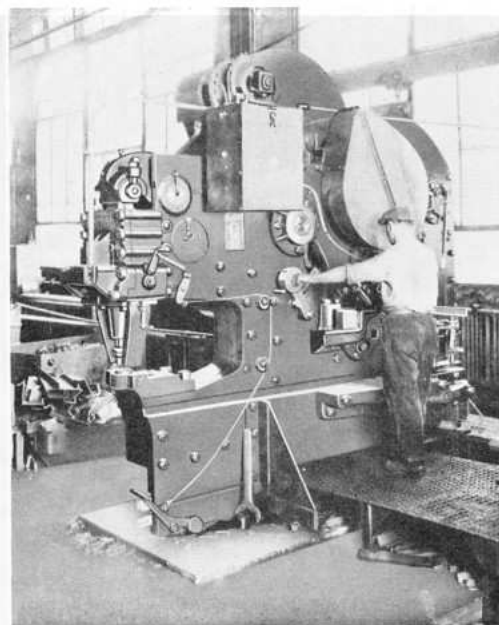

No. 3 1/2 U.D. Machine.

Buffalo

Buffalo Combination Woodworking Machines

THE Buffalo No. 1 and No. 2 Combination Woodworking Machines shown in this section have been on the market for many years. They are sturdily built throughout and recent improvements in both design and construction have added to their popularity. Years of hard usage have demonstrated their ability to stand up under continuous hard service.

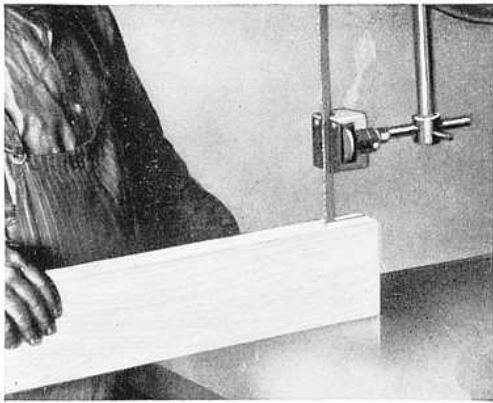

Resawing With Band Saw

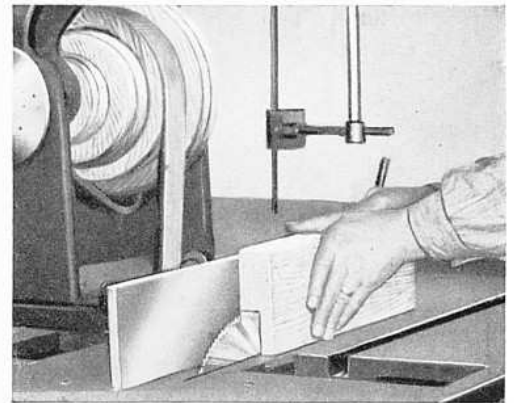

Mortising With Circular Saw

“Buffalo”

No. 1 Woodworker

Three men can work on this efficient machine at one time without interfering with one another. Practically any woodworking operation can be performed upon it without any attachment except the changing of tools. It will keep them busy all day at about one-third the cost of special machines. Because of its sturdy efficient construction it occupies very little space, thereby saving valuable floor space for other uses.

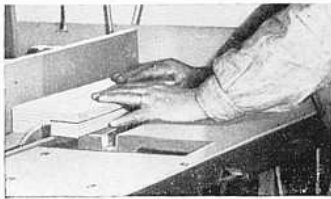

Mortising



Cross-Cutting at Angle With Circular Saw

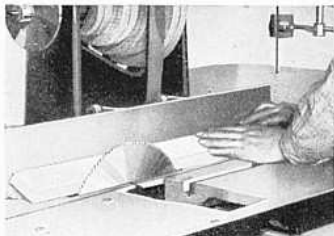

Ripping Bevel With Circular Saw

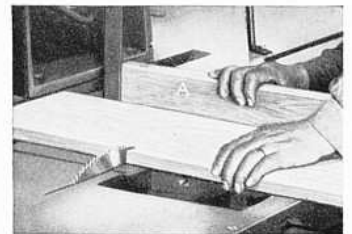

Cross-Cutting With Circular Saw

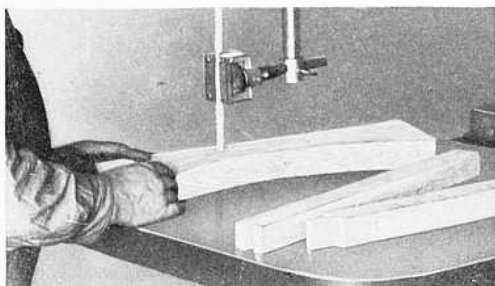

Note Sturdy Construction of Adjustable Guide on Band Saw

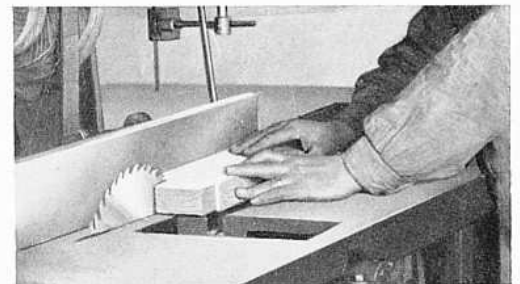

Note Convenience of Adjustable Guide

“Buffalo”

The Complete Buffalo Woodworker No. 1

TEN MACHINES IN ONE

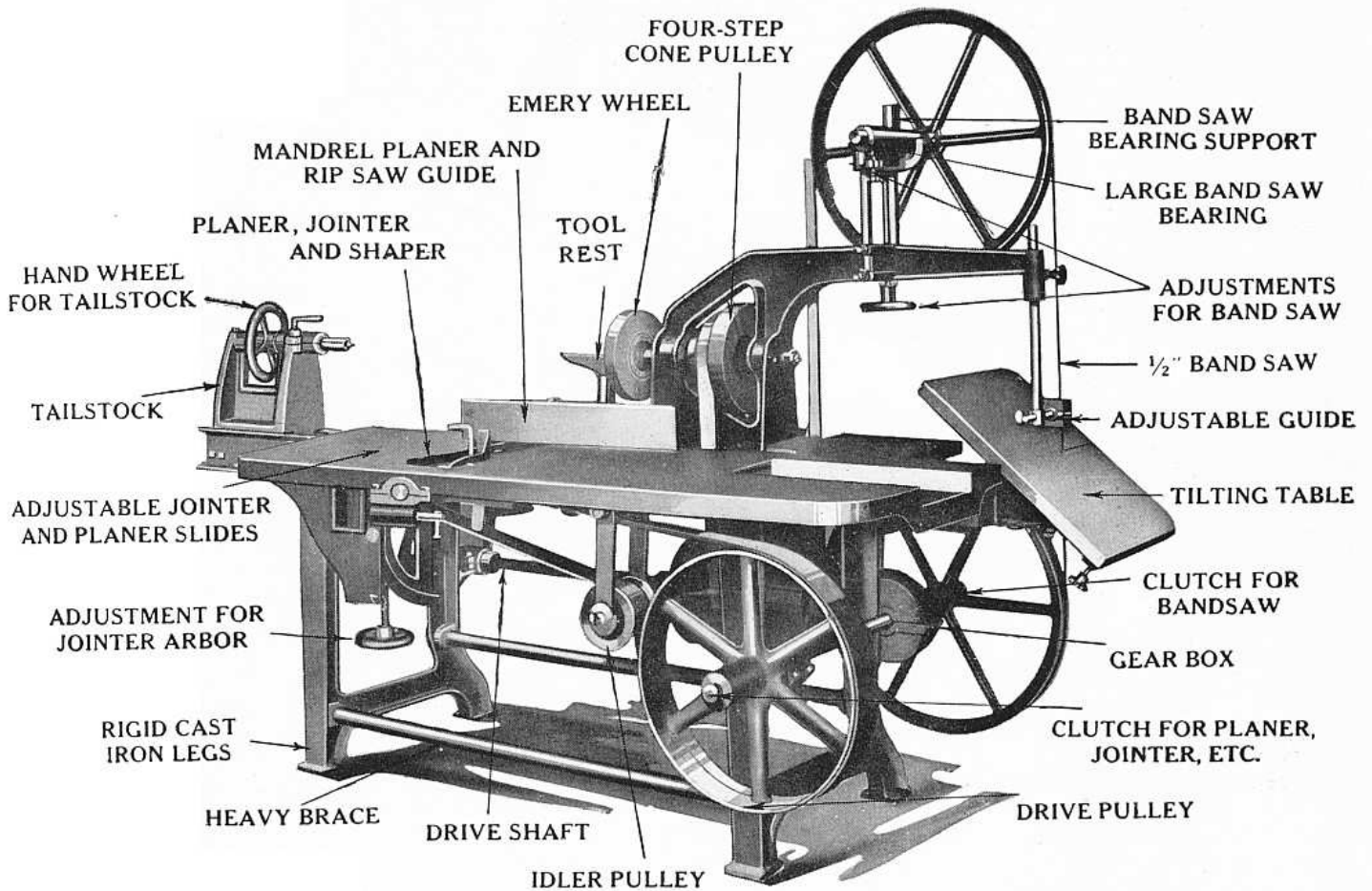

This No. 1 Combination Woodworking machine, as illustrated, is a great favorite in shops where a large woodworker is needed. It has both a rip and cross-cut saw, band saw, jointer, shaper or edge moulder, drill and grinder. A sander can be furnished at slight additional charge.

The rip and cross-cut saws are 12" in diameter and will make a cut up to 3½" deep. Drive shaft 350 R.P.M. Standard equipment includes lathe, 22" swing, 42" between center, 10" planer head, band saw, rip, cut-off saw, belts and necessary guide.

In construction, the No. 1 Woodworker is a husky, well made machine, that will stand the severe service to which such machines are subjected.

Buffalo

Operation of Machine

Tight and loose pulleys are provided on the main shaft, at the left of the cone pulleys below the table. This construction makes it possible to run the belt up thru the table to a line shaft or motor overhead.

There are three distinct parts to the machine which may be operated individually or together. (1) The lathe, also used for drilling and grinding. (2) The band saw. (3) The arbor, used for circular saw, planer, sander, jointer and shaper. The main parts are engaged by means of three conveniently arranged clutches. The main drive is provided with a belt-shifter which can be operated from either side of the machine. With all parts of the woodworker operating at once, only 4 to 5 H. P. are required.

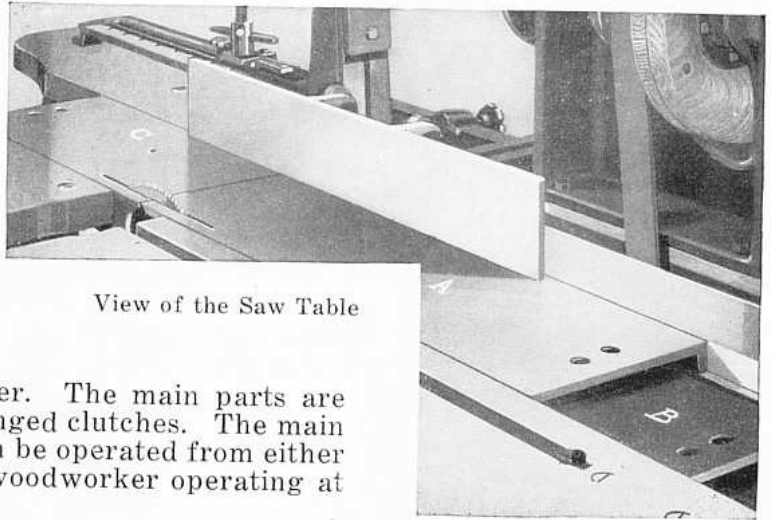

View of the Saw Table

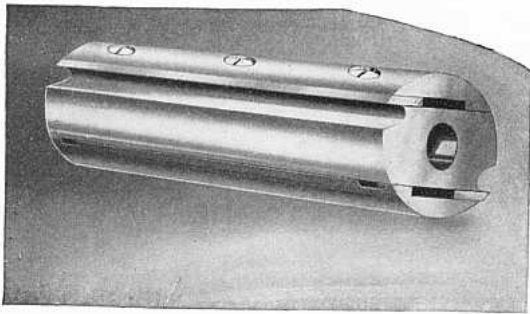

10-Inch Planer Head

Planer, Jointer, Shaper and Saw Mandrel: The No. 1 Combination Woodworker has an adjustable mandrel which can be run horizontally or vertically and on which may be inserted planer and dado heads, and circular saws and knives of any size. The mandrel is cold-rolled steel, machined and pivoted so that it swings easily to a horizontal or vertical position. Runs in long babbitted bearings, which have adjusting screws and liners to take up wear. A crown pulley, three inches in diameter is driven from the large pulley below the table. Starting and stopping are controlled by a clutch on the large pulley.

Planing and Joining: The planer table is made in two parts which fit into the channel of the main table and are horizontally adjustable to give access to mandrel or to allow it to be set vertically for shaping. One part of the table may be set at a lower level when planing to obtain the desired depth of cut. An adjustable guide for the planer is furnished which can be set at a 90° angle with the table top or tilted back to allow planing at an angle.

A 10-inch planer head with knives is furnished with the machine. The planer slides are 29x10 inches and 21x10 inches respectively.

Shaper: With the mandrel raised to a vertical position a shaper is obtained on which any kind of knives may be used. We furnish one pair of chamfering bits and one pair of rounding bits as the 10-inch planer head can only be used in the horizontal position. When sizing lumber, the gauge is set at the desired distance from the edge of the knives, and the lumber run thru between.

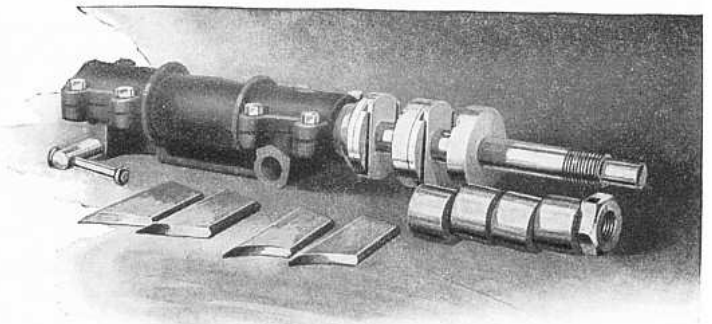

Mandrel for Jointer, Shaper and Circular Saw

Buffalo

By dropping the spindle partly below the level of the table, panels of various widths can be raised. The shaper will take knives for working mouldings of any shape, for dadoing, tonguing, grooving, rabbetting, pole-rounding, etc. For use with the shaper we furnish an attachment to the main gauge which enables the operator to stand at the side of the table and run the work past the knives, at the front, instead of between the knives and the main gauge. This extension gauge is furnished only when ordered at a small extra charge.

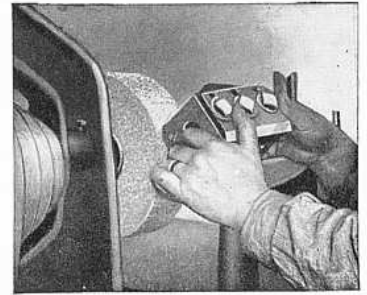

The grinder is
a useful accessory

Rip and Cut-Off Saw: Twelve-inch rip and cut-off saws are furnished with the machine. Cuts of any desired depth up to $3\frac{1}{2}$ inches may be made. The gauge provided may be used as a ripping fence. By shimming up the work, it is possible to saw on a bevel.

The removable gauge for cross-cutting has quadrant which permits adjustment for sawing at any angle from 30° to 90° .

The Lathe: The lathe, for wood turning, will handle work up to 20 inches in diameter by 40 inches long and has four step cone pulley $5\frac{1}{4}$ "- $7\frac{1}{2}$ "- $9\frac{3}{4}$ " and 12" in diameter within 2-inch pulley face, thus giving a variety of speeds.

A clutch is provided on lower cone pulley for controlling stopping and starting. Regular equipment includes a tool rest which slides along the table and acts as guide while using lathe, one spare center and one face plate for holding work in lathe.

Drill: A chuck is furnished with each machine which fits on end of lathe spindle and will take standard $\frac{1}{2}$ " straight shank drill bits.

Either a disc sander or an emery wheel can easily be fastened to the lathe spindle making very useful accessories. Grinding wheel is furnished with machine. Disc sander can also be furnished at an extra charge.

The Band Saw: The band saw is cast in one piece with the main table, and is planed true and level. It measures $29\frac{1}{2}$ x 30 inches. The saw wheels are 27 inches in diameter and the maximum clearance below the guide is 15 inches. The saw is furnished with an anti-friction adjustable guide which can be removed entirely if desired. One $\frac{1}{2}$ -inch band saw is furnished with the machine, altho other size saws can be used.

A clutch on the lower saw wheel provides a convenient means of starting and stopping. The band saw is as strongly constructed as it would be in an individual machine; the shaft is $1\frac{3}{8}$ inches diameter; the upper bearing is 10 inches long.

Specifications

Buffalo No. 1 Complete Woodworker with iron table, accurately planed mandrel, and 10-inch planer head and knives.

Greatest dimensions of table, 8'-7" long x 4'-7" wide.

Height of table, 36 inches.

Greatest over-all length of machine, with carriage pulled out, 12 feet.

Shipping weight, 2,000 lbs.

Drive pulley should run 350 R.P.M.

"Buffalo"

The Combination Buffalo Woodworker No. 2

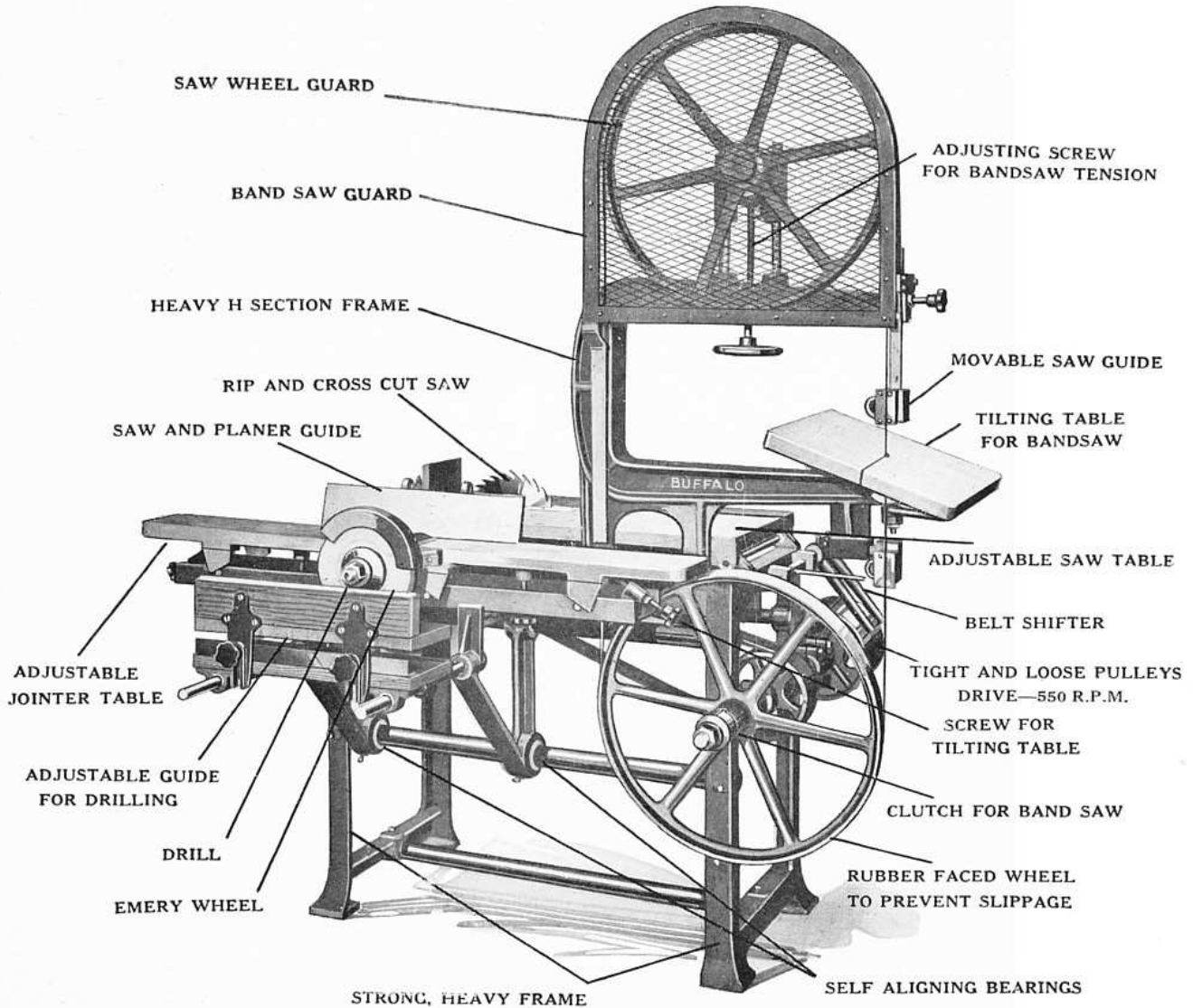

The entire construction of the Buffalo No. 2 Combination Woodworker, is of the highest grade. The frame proper is made of heavy cast iron and rigidly braced. Bearings throughout are large, and babbitted, with provision for lubricating. Tables are finished perfectly smooth. Band saw wheels are balanced, so as to run safely at high speeds without vibration. Band saw wheel bearings are extra long, and the upper bearing is adjustable by means of the hand wheel shown.

This combination woodworker is adaptable to many different jobs. Contractors find it convenient to take from place to place, or to set up in their shops. Carpenters have found it cuts the labor costs on new buildings to a fraction. In foundries, it is used for making and repairing flasks, core boxes and patterns, as well as for many other jobs, bracing, making bins, etc. Three men can perform different operations at one time without interfering with each other.

Many shipping rooms find this machine excellent for cutting crating lumber. Blacksmiths and wagon-makers also find the No. 2 Woodworker a very useful machine.

Buffalo

Rip and Crosscut Saw:

The table for the rip and crosscut saw is 37 inches wide, of heavily ribbed cast iron. The saw mandrel is $1\frac{1}{16}$ inches diameter and runs in babbitted and reamed bearings $4\frac{3}{4}$ inches long and provided with oil grooves. The saw pulley is $2\frac{3}{4}$ inches diameter, a $2\frac{1}{2}$ -inch belt is used, with a speed of 3000 R.P.M. Belt from drive shaft to saw mandrel furnished with machine.

The saw table is hinged at one end for raising and lowering to adjust the depth of the cut. (See illustration.) The cast iron side guide, which will tilt to any angle, may be swung over and used in con-

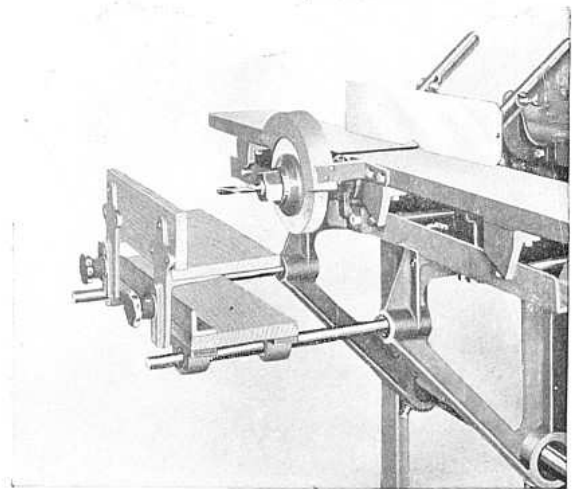

Grinder wheel and drill with grinder guard and drilling table. Observe the adjustable feature of the drilling table.

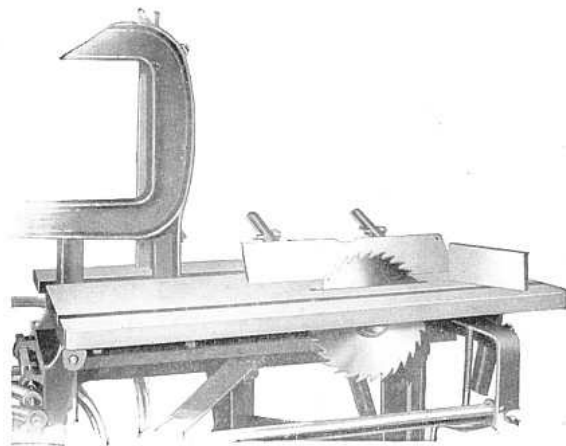

Rip and Cross-Cut Saw—Table tilted. Note smooth even finish and sturdy construction.

A screw and handwheel arrangement are used to make both sides of the jointer table adjustable.

These tables are 6 inches wide and 24 inches long, each allowing for very accurate work. The jointer shaft has an outboard bearing and outside of this an $8 \times \frac{3}{4}$ inch emery wheel may be attached by means of two collars and a nut.

nection with the jointer. A cast iron cross-cut guide is also furnished which slides in a milled groove in the table and is adjustable for different angles. The saw will make a cut $2\frac{3}{4}$ inches deep.

Jointer:

The jointer is fastened on the same spindle as the saw, is 6 inches long and 3 inches in diameter. Our jointer is, of course, of the rounded safety type.

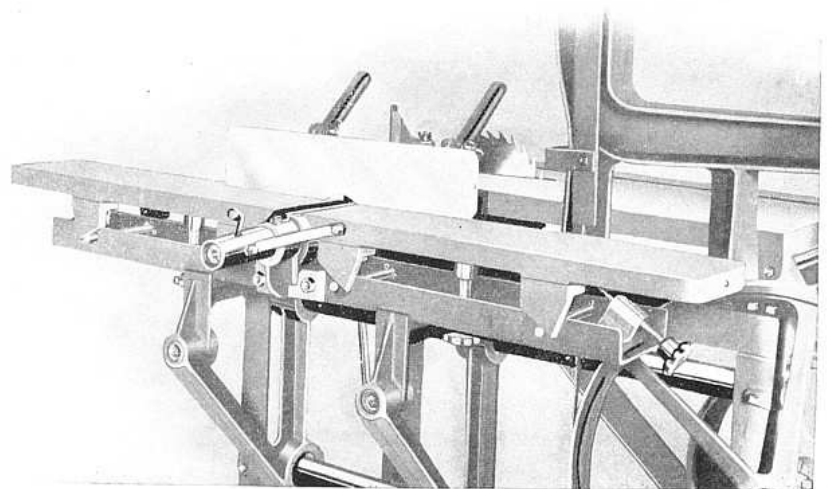

Close-up of the jointer, showing the adjustable tables. At the left front of the machine you will notice the brackets for holding the slide table for drilling.

“Buffalo”

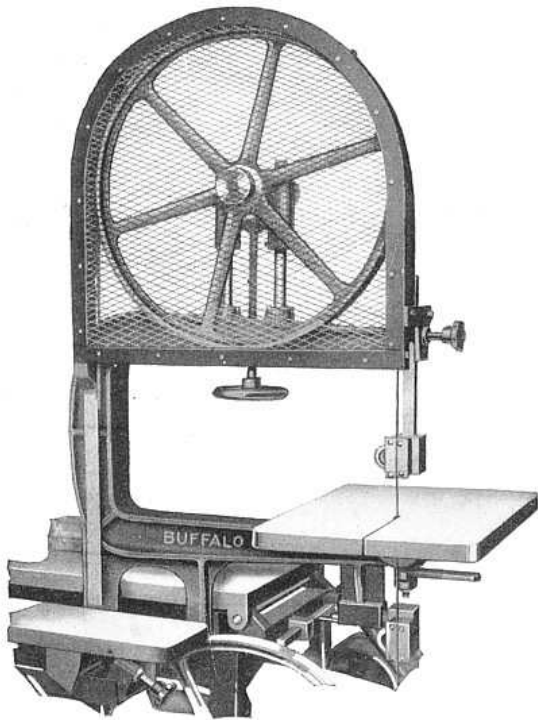

Close-up of the band saw. The heavy frame, balanced wheels, adjustable bearing and rigid, sturdy guide enable this saw to stand a lot of hard usage.

saw frame, and a hand wheel screw is provided under the bearing for maintaining a tension on the saw.

The saw guide consists of a tempered and ground tool steel disc with an extension which runs in a long reamed hole. The guide is readily adjustable for material up to several inches thick. A $\frac{3}{8}$ -inch band saw is regular equipment but wider or narrower ones can be used if the nature of the work requires it.

The following are furnished as regular equipment:

- A $\frac{3}{8}$ -inch band saw.
- 10-inch rip saw.
- 8x $\frac{3}{4}$ -inch emery wheel.
- 6x3-inch safety planer head.
- Wrench for planer head.
- Belt for rip saw and planer.
- Band saw guide.
- Emery wheel guard.

The saw throat is 21 $\frac{1}{2}$ inches.
2 H.P. required to operate.
Shipping Weight, 830 lbs.

Drill and Sander:

The shaft end is provided with a $\frac{1}{2}$ -inch reamed hole and tap for a headless set screw. This allows straight shank bits to be inserted. In order to facilitate holding work to be drilled, a slide table is provided which is readily adjustable to different heights. The guide bars for this table fit in reamed holes in the bracket of the machine. Thus the guide can easily be removed when not in use.

An 18-inch disc sander may be placed on the threaded drive shaft end if desired.

Band Saw:

The band saw on this machine is furnished with a well-finished cast iron tilting table 17 $\frac{1}{2}$ inches long by 14 $\frac{1}{4}$ inches wide. Absolute rigidity of the table is assured, as there are three ribs running the full length of it. It may be locked in any position by means of a positive-action cam and handle.

The band saw wheels are turned and balanced, 22 inches in diameter with a 1 $\frac{1}{2}$ -inch face. The face of each wheel is covered with an endless rubber band on which the saw runs. This eliminates slippage of the saw, and reduces the heat from the blade.

Saw Frame:

The frame of the saw is made of cast iron in an H section, which is the strongest construction known. The saw throat is 21 $\frac{1}{2}$ inches deep. An adjustable bearing for the upper wheel is mounted on top of this

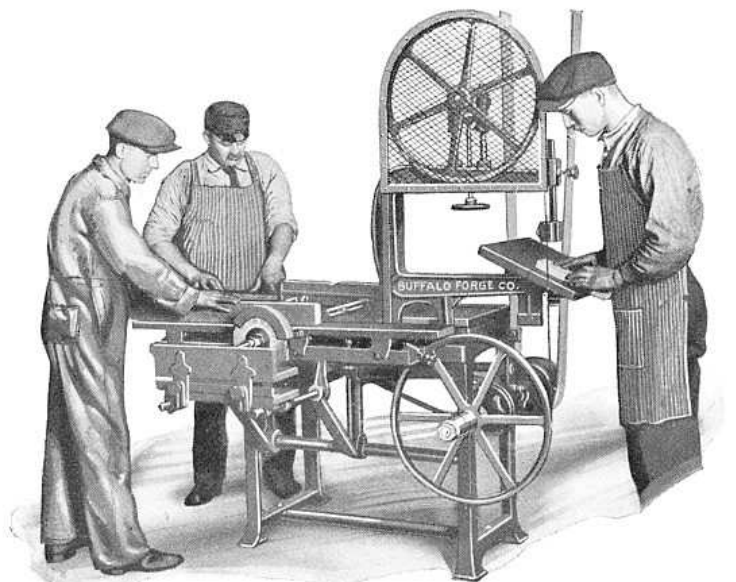

These men are busily engaged operating band saw, rip saw and jointer, a common sight in shops where our woodworking machines are used.

"Buffalo"

Buffalo Blowers and Exhausters

IN this section we show Buffalo blowers and exhaust fans, which are largely stock machines, ready for immediate shipment. They are designed for economy in power, lasting service, and for the greatest convenience in care, operation and repair. In all cases special attention is given to the balancing of the blast wheels, so that vibration may be avoided; each blower is given a running balance before shipment. The pulleys furnished are of standard sizes with correct proportions for the speed and horsepower needed.

For engineering data not contained in this section we ask that you refer to our engineering department.

Buffalo Volume Fans

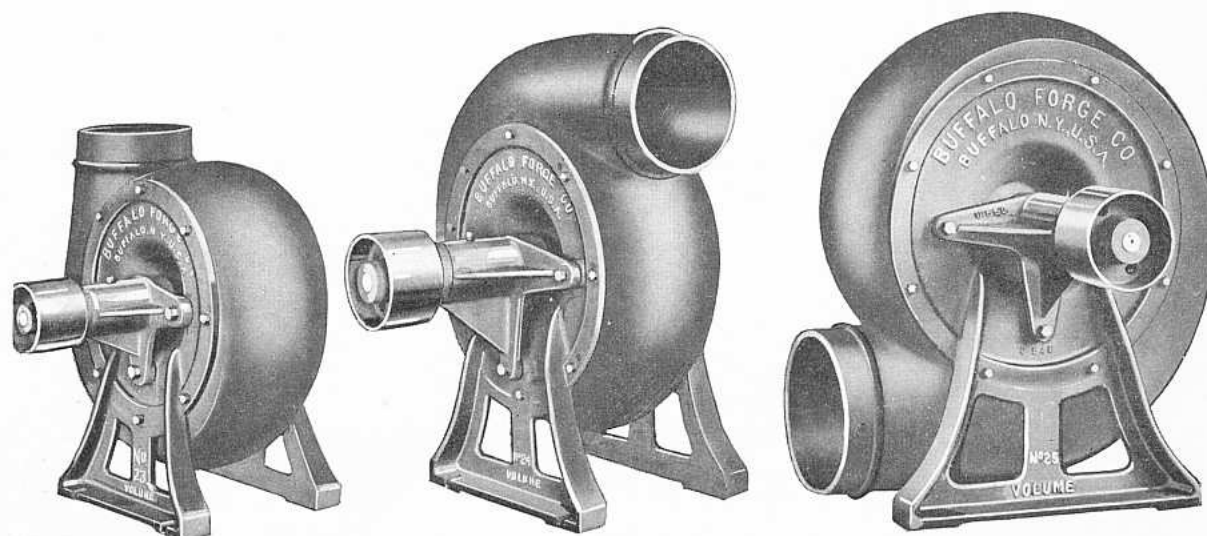

Three of the eight positions to which the housing of Buffalo Volume Fans can be adjusted. Change is made by simply unbolting the side plates and swinging the housing to the desired position. See Page sixty-one for other arrangements.

Buffalo Volume Fans are a new development from the "B" Volume Blowers and Exhausters which have been popular for so many years. The Volume Fans are equipped with ball bearings, giving better efficiencies, and are adjustable to eight different positions of discharge and to either clockwise or counter clockwise rotation. The one fan can be used as either a blower or exhauster.

Side plates and feet are cast in one piece to permit adjusting the housing to any desired direction of discharge.

Heavy duty, dust-proof ball bearings with deep raceways in both inner and outer rings, insure efficient, trouble-free running.

Volume Fans have the solid peripheral shell construction that made "B" Volume Fans so popular. They are rigid and compact and resist deterioration from moisture, heat, acid fumes, or gritty dust.

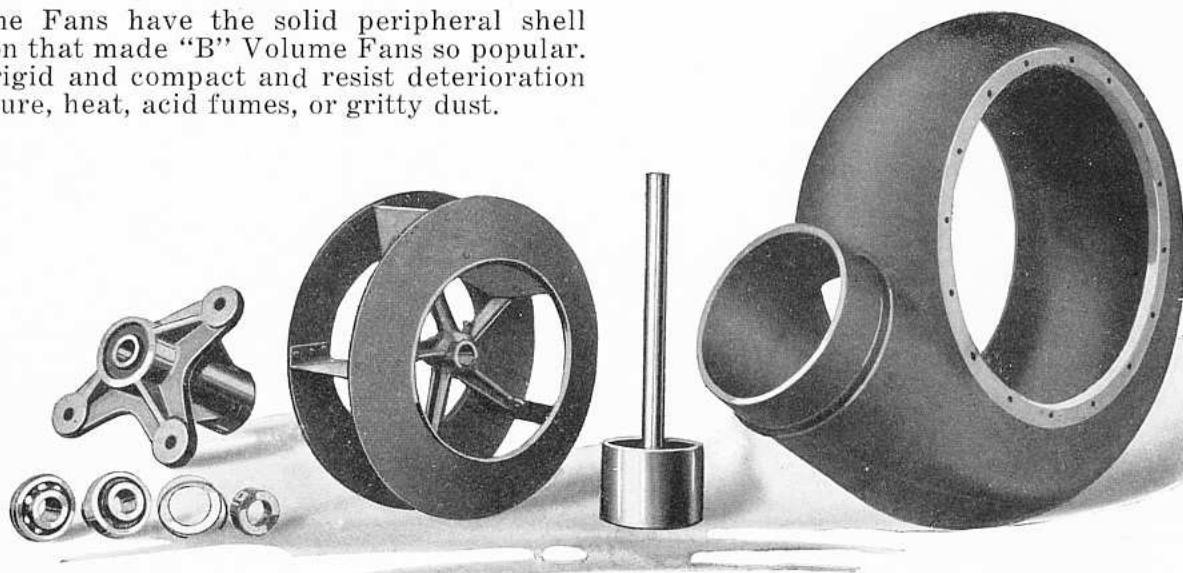

Note the simplified plan of assembly. The steel wheel blades are securely riveted to the malleable iron spider and to the steel side plates. Shaft carried by heavy duty ball bearings.

Buffalo Volume Fans with Direct Motor Drive

The arrangement for motor drive is an attractive feature of the new design of Buffalo Volume Fans. A special center plate casting with an adjustable support is used to mount the direct connected motor, replacing the bearing arm. This eliminates the need of a cast iron sole plate, saving size and weight and still retaining the reversible housing feature.

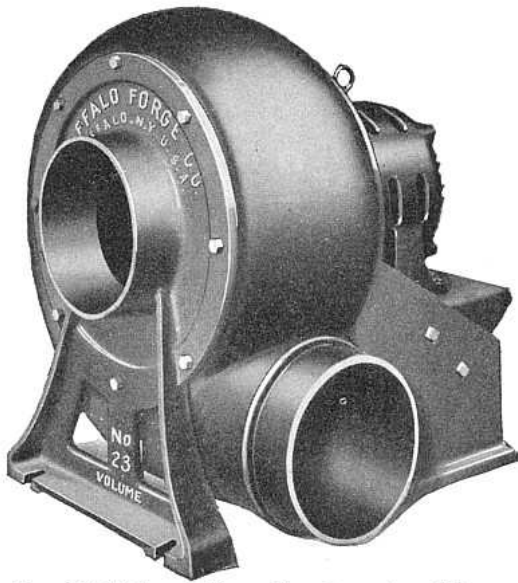

No. 23 Volume Fan, direct motor drive.

A Few of the Uses for which Buffalo Volume Fans Are Especially Adapted:

Burning Sawdust, Conveying Material, Drying Systems, Emery and Polishing Wheels, Exhausting Smoke, Forced Draft, Forge and Furnace Blast, Fume Exhaust, Hollow Blast Grates, Mine Ventilation, Organ Blowing, Shavings Exhaust Systems, Toilet Ventilation, Vapor Removal.

The one fan can be used for either blowing or exhausting.

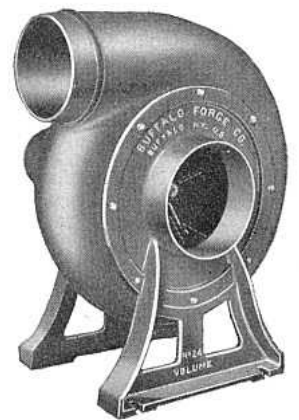

No. 24 Volume Fan, showing inlet side.

Capacities, Speeds and Horsepower of Volume Fans

Fan No.	1" S.P. .58 oz.			2" S.P. 1.16 oz.			3" S.P. 1.73 oz.			4" S.P. 2.31 oz.			5" S.P. 2.89 oz.		
	A.P.M.	R.P.M.	H.P.	A.P.M.	R.P.M.	H.P.	A.P.M.	R.P.M.	H.P.	A.P.M.	R.P.M.	H.P.	A.P.M.	R.P.M.	H.P.
21	179	1765	.05	253	2498	.13	310	3063	.24	358	3533	.36	400	3925	.51
22	279	1413	.07	395	1998	.20	485	2470	.37	560	2825	.57	625	3160	.80
23	472	1087	.12	669	1538	.34	821	1885	.63	946	2173	.96	1059	2431	1.35
24	650	927	.17	921	1311	.47	1130	1610	.87	1303	1855	1.32	1458	2073	1.86
25	906	785	.23	1283	1110	.65	1575	1361	1.21	1817	1570	1.84	2030	1756	2.59
26	1320	649	.34	1870	917	.95	2293	1126	1.76	2640	1299	2.68	2960	1451	3.78
27	2235	500	.57	3160	706	1.60	3880	866	2.98	4475	1000	4.54	5000	1118	6.38
28	3723	387	.95	5274	547	2.67	6475	671	4.97	7460	775	7.56	8350	865	10.65
29	6310	298	1.60	8940	421	4.53	10980	516	8.43	12660	595	12.81	14150	665	18.05

Fan No.	6" S.P. 3.47 oz.			7" S.P. 4.05 oz.			8" S.P. 4.62 oz.			9" S.P. 5.19 oz.			10" S.P. 5.77 oz.		
	A.P.M.	R.P.M.	H.P.	A.P.M.	R.P.M.	H.P.	A.P.M.	R.P.M.	H.P.	A.P.M.	R.P.M.	H.P.	A.P.M.	R.P.M.	H.P.
22	685	3463	1.02	740	3740	1.30	791	3997	1.61	842	4054	1.92	893	4111	2.23
23	1160	2665	1.73	1252	2874	2.22	1340	3074	2.72	1418	3258	3.24	1496	3435	3.80
24	1598	2273	2.38	1722	2452	3.06	1842	2623	3.74	1952	2780	4.46	2060	2930	5.22
25	2225	1924	3.31	2400	2075	4.26	2567	2220	5.21	2720	2352	6.21	2868	2480	7.28
26	3240	1590	4.82	3492	1716	6.20	3740	1835	7.60	3960	1945	9.05	4175	2050	10.60
27	5490	1224	8.15	5910	1321	10.50	6320	1413	12.85	6700	1499	15.31	7060	1580	17.95
28	9150	950	13.60	9860	1023	17.52	10550	1090	21.40	11180	1160	25.50	11800	1223	29.90
29	15500	730	23.10	16720	786	29.70	17900	841	36.30	18950	890	43.30	20000	940	50.75

S.P. is static pressure.

A.P.M. is cu. ft. of air per minute.

H.P. is power required to deliver air at pressure given.

Buffalo

Specifications for Buffalo Volume Fans

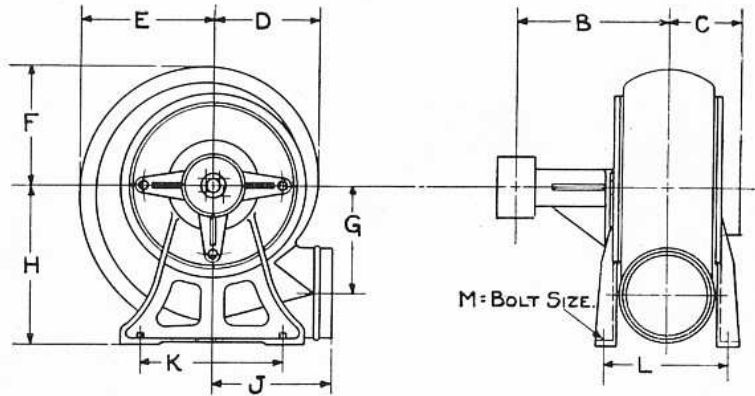

Dimensions in Inches

No.	B	C	D	E	F	G	H	J	K	L
21	9 1/8	4	5 3/8	6 2/8	5 7/8	5 1/8	8	6 1/8	6 1/2	7
22	11 1/8	5 1/4	6 1/8	8 3/8	7 3/8	6 1/4	10	7 3/4	7	8 3/4
23	11 1/8	6 1/8	8 1/2	10 1/8	9 1/8	8 1/8	12 7/8	10	10 1/2	10 3/4
24	14 1/4	6 1/4	9 7/8	12 3/8	11 1/8	10 1/8	15	11 1/4	13	12
25	14 1/4	7 5/8	11 5/8	14 5/8	13 1/8	11 7/8	17 3/8	12 1/2	16	13 1/4
26	19 1/4	9 1/4	14 1/8	17 3/4	15 7/8	14 1/8	21	15 1/4	19 1/2	18
27	19 1/4	11 5/8	18 1/8	22 1/4	20 1/8	18 1/8	27	19 1/2	26	23
*28		15	23 1/8	29 3/8	26 1/4	23 7/8		28		
†29		18 3/8	30 1/8	38 1/8	34 1/8	30 7/8		35 1/2		

*Fan No. 28 has ball bearing arm but is not reversible.

†Fan No. 29 has bearings on pedestals and is not reversible.

Nine sizes cover a wide range of requirements. Increase from one size to another is uniform so that the capacities, speeds and pressures and power ratings of the different sizes bear a definite relation to each other.

Dimensions in Inches

No.	Outlet Diameter Outside	Inlet Diameter Outside	Pulleys		Weight Pounds
			Diameter	Face	
21	4 1/2	5	3	2 1/2	65
22	5 1/2	6	4	3	110
23	7 1/2	8	4	3	165
24	8 1/2	9 1/8	5 3/4	3 5/8	250
25	10	10 1/2	5 3/4	3 5/8	350
26	12	12 3/4	7 1/2	6 1/2	500
27	16	16 3/4	7 1/2	6 1/2	880
28	20	20 7/8	9 1/2	8 1/4	1900
29	26 1/2	26 3/4			4500

Buffalo

Buffalo Steel Pressure Blowers

Made in twelve sizes, with a wide range of capacities, the smaller steel pressure blowers are used extensively for supplying air to cupolas and forge fires and also for burning pulverized coal or fuel oil. Other uses include mould-cooling in gas plants and supplying air to malleable iron furnaces. The smaller fans are capable of delivering air at pressures up to 6 to 8 ounces, while the larger ones are capable of delivering against pressures up to a maximum of 16 ounces.

Buffalo steel pressure blowers have a heavy cast iron shell, of solid peripheral construction, with easily removable center plates, permitting the blast wheel to be read-

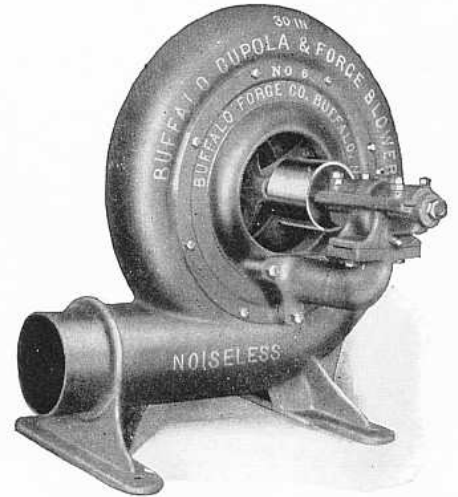

Steel Pressure Blower—Pulley Driven

ily removed or inspected without disturbing the blower on its foundations. This is one of the distinguishing features of Buffalo steel pressure blowers.

All fans up to and including the No. 6 are equipped with one pulley. The larger sizes have two pulleys, one on each side of the shell. All standard blowers have bottom horizontal discharge. The blowers having one pulley have the pulley located on the right hand side of the shell when standing facing the discharge, and are designated as clockwise bottom horizontal discharge. As the larger

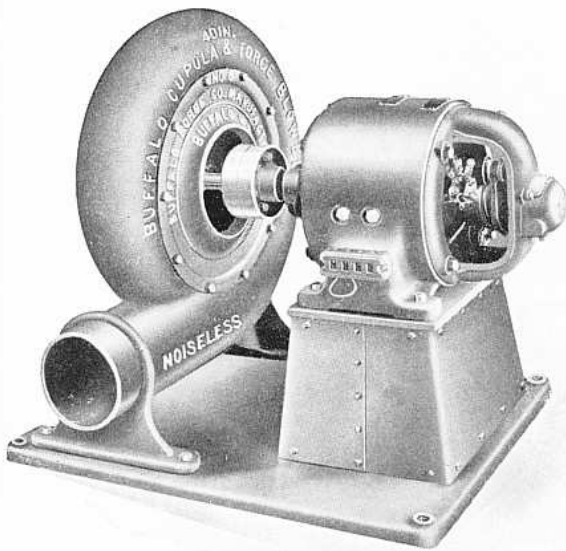

Motor Driven Steel Pressure Blower (Type P)

sizes have two pulleys, it is only necessary to designate the discharge when ordering. Either clockwise or counter-clockwise can be furnished at the regular price, but all discharges other than bottom horizontal are special, usually having to be made up, and there is an extra charge of 10% on account of special core boxes being required for casting, while the standard blowers are manufactured in large quantities.

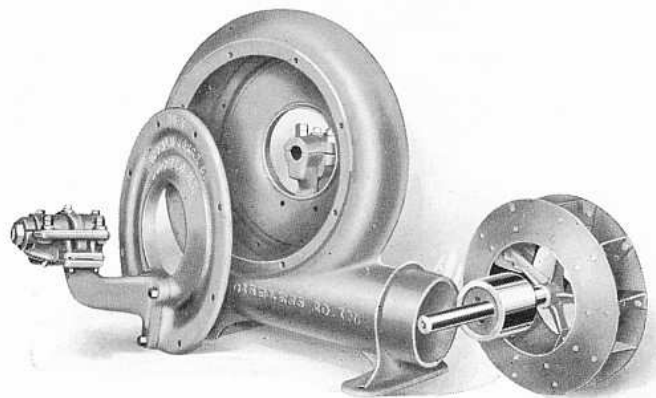

Parts of Steel Pressure Blower

Buffalo

Buffalo Steel Pressure Blowers

Table of Capacities with Speed and Horse Power Requirements

No. of Blower	3 Oz.			4 Oz.			5 Oz.			6 Oz.			7 Oz.			
	R.P.M.	Cap.	H.P.	R.P.M.	Cap.	H.P.	R.P.M.	Cap.	H.P.	R.P.M.	Cap.	H.P.	No. of Blower	R.P.M.	Cap.	H.P.
2	4320	247	0.53	4990	285	.81	5595	320	1.01				4	4395	785	3.05
3	3420	490	0.81	3950	565	1.25	4435	635	1.75	4840	690	2.3	5	3870	890	3.38
4	2880	520	0.86	3330	600	1.32	3730	670	1.85	4065	730	2.40	6	3360	1160	4.42
5	2540	580	0.96	2930	670	1.47	3290	755	2.06	3585	825	2.70	7	2985	1375	5.25
6	2190	755	1.24	2550	880	1.94	2860	985	2.70	3115	1076	3.52	8	2710	2080	7.93
7	1940	895	1.46	2255	1045	2.27	2535	1170	3.32	2765	1275	4.15	9	2425	2940	11.2
8	1763	1353	2.20	2050	1570	3.43	2300	1765	4.80	2510	1925	6.28	10	1815	4305	16.4
9	1577	1913	3.13	1840	2225	4.84	2060	2500	6.80	2245	2720	8.87	11	1510	5300	20.3
10	1180	2797	4.56	1375	3255	7.09	1540	3655	9.93	1680	3990	13.0	11 1/2	1200	5940	23.4
11	985	3450	5.63	1145	4010	8.74	1285	4515	12.3	1400	4915	16.1	12	1230	6880	26.3
11 1/2	778	3860	6.5	907	4500	10.1	1020	5040	14.1	1110	5500	18.5				
12	799	4478	7.3	930	5210	11.3	1045	5840	15.9	1135	6380	20.8				

No. of Blower	8 Oz.	10 Oz.	No. of Blower	12 Oz.	14 Oz.	16 Oz.
R.P.M.	Cap.	H.P.	R.P.M.	Cap.	H.P.	R.P.M.
5	4130	950	4.14			
6	3585	1240	5.42	4000	1385	7.55
7	3180	1470	6.40	3560	1640	8.90
8	2890	2220	9.66	3225	2480	13.6
9	2585	3135	13.7	2890	3500	19.0
10	1935	4590	20.0	2160	5135	27.9
11	1615	5660	24.7	1800	6320	34.4
11 1/2	1280	6350	28.5	1425	7150	40.2
12	1310	7350	32.0	1460	8200	44.6
6	4380	1510	9.90			
7	3880	1790	11.7	4380	1510	9.90
8	3525	2705	17.6	3880	1790	11.7
9	3155	3825	25.0	3525	2705	17.6
10	2360	5595	36.5	3155	3825	25.0
11	1970	6900	45.0	2360	5595	36.5
11 1/2	1555	7720	52.0	1970	6900	45.0
12	1595	8955	58.4	1555	7720	52.0
				1595	8955	58.4

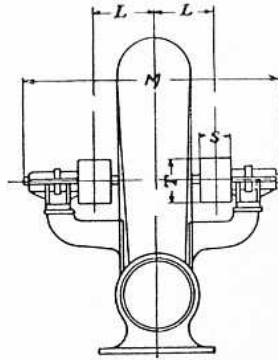
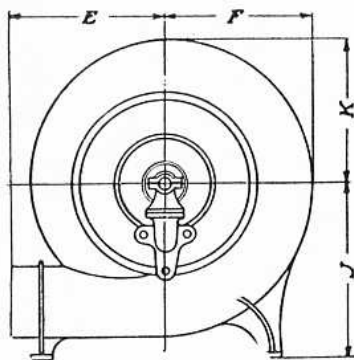

**Clockwise
Bottom Horizontal
Discharge**

Dimensions in Inches

Size No.	Outlet Diameter Outside								PULLEYS	
		E	F	J	K	L	M	Weight	Diameter	Face
1	3 1/2	6 1/8	5 1/4	6 7/8	5 1/8	3 1/2	14 1/4	55	2 1/4	1 3/4
2	4	7 1/8	6 3/8	9 1/8	5 1/8	3 3/4	19 1/2	75	2 3/4	2 1/4
3	4 5/8	11 1/8	8 1/4	10 3/4	8 5/8	4 5/8	23	95	3	2 5/8
4	5	13 1/8	10 3/8	13 1/2	9 1/8	5 1/8	25 1/4	135	4	3
5	5 3/8	14 1/4	11 1/8	14 1/4	11 1/2	4 1/2	24 1/2	180	4 1/4	3
6	6 1/8	15 3/4	13 1/4	16 5/8	12 5/8	5 3/8	27 1/2	265	4 1/2	3 1/2
7	7 1/4	16 3/4	15 3/8	19	14	6 1/4	34	308	5	4 1/2
8	8 1/8	19 1/8	17 3/8	21 7/8	16 3/8	8 5/8	40	445	6	4 1/2
9	10	22	20	24 3/4	18 7/8	9 3/8	41 1/2	635	7	5
10	12 1/8	27 5/8	25 3/8	30 1/8	25 1/2	10 3/8	45	820	8	5 3/4
11	14 3/8	27 1/2	30 7/8	36	29 1/8	11 1/8	50	1400	8 1/2	6 1/2
11 1/2	16 3/4	33 1/4	35 3/8	41 1/4	34	12 1/4	53 1/4	1900	10	7
12	18	33	35 7/8	41 1/4	34	12 3/8	53 1/4	1950	10	8

Nos. 1 to 6 have but one pulley, while all larger sizes have two pulleys, as shown above.



Buffalo Standard Reversible Steel Plate Mill Exhausters

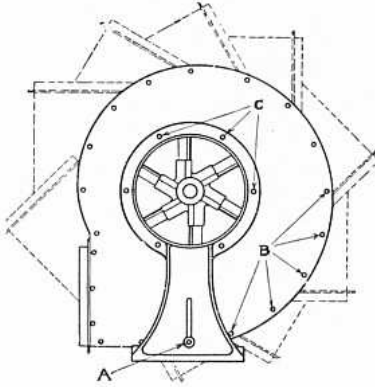

These exhausters have reversible housings, adjustable to either rotation and to any change of discharge. To change the direction of discharge, it is only necessary to loosen the hook bolts "C" in the ring of each pedestal and take out bolt "A," then revolve the housing until the discharge points in the desired direction. To change the direction of rotation remove the hook bolts "C," loosen set screws holding the blast wheel to shaft, then shift the pedestals.

The advantages are self-evident. One fan may be used to meet any requirement, eliminating the necessity for crossed belts and avoiding all sharp angles. To the mill owner this is desirable, because it is frequently necessary to change the position of the fan, due to alterations or enlargement of the piping and building. And dealers need not carry in stock fans of each rotation and angle of discharge.

Heavy rolled steel plate, securely bolted together with angle irons, is used in the construction of the housing. A round steel outlet is bolted to the housing. Blast wheel is mounted upon a heavy cast iron spider. Spokes are of Tee steel, cast into the hub. Heavy steel plate blades are riveted to these spokes, reinforced by securely riveted side flanges.

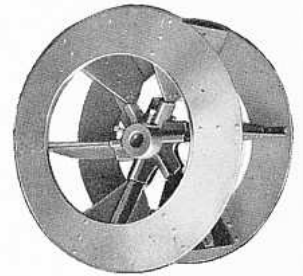

Standard Blast Wheel

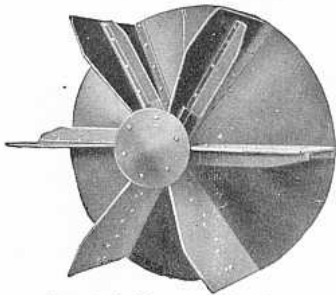

Special Long Shaving
or Cone Wheel

When heavy, bulky or abrasive material is to be handled, extra heavy blast wheels are furnished. For handling long shavings and similar stringy material the cone type wheel is recommended.

Every wheel is balanced by our special method which insures smooth running and absence of vibration, and is tested at speeds far beyond those required in practice.

Bearings are self-aligning vertically and are bolted to the pedestal in such a way that considerable adjustment is possible horizontally, making the bearings to all practical purposes self-aligning in both directions.

The journal, five diameters in length and lined with the best white metal, has two chambers for the oil rings. These rings constantly carry oil to the shaft. It is impossible for the bearings to be without lubrication as long as there is oil in the chambers. The rings operate perfectly quiet until oil becomes low. Any noise, therefore, is a signal for re-oiling.

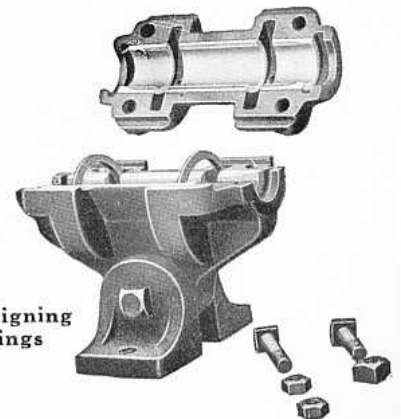

Details of Buffalo Self-aligning
Double Oil-Ring Bearings

"Buffalo"

Buffalo Direct-Connected Mill Exhausters

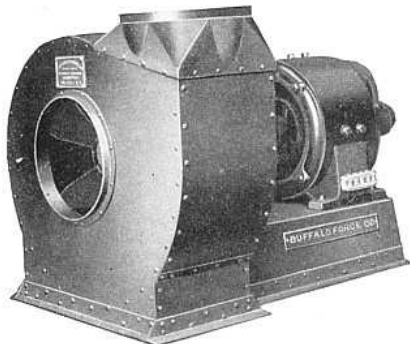

Up-Blast Standard Mill Exhauster, Direct Connected to Electric Motor

Buffalo direct-connected outfits can often be used to advantage since belting is avoided and floor space economized. The motor is placed on a sheet steel sub-base rigidly attached to the housing, making a single complete unit, impossible to get out of alignment. These outfits may be mounted on platforms near the ceiling, a convenient location as it is desirable to keep the main discharge pipe close to the ceiling. In requesting quotations, give characteristics of electric current available.

Rubber-Lined Mill Exhausters—For handling corrosive fumes, these fans can be furnished coated with pure live rubber, vulcanized to steel shaft and inside of housing.

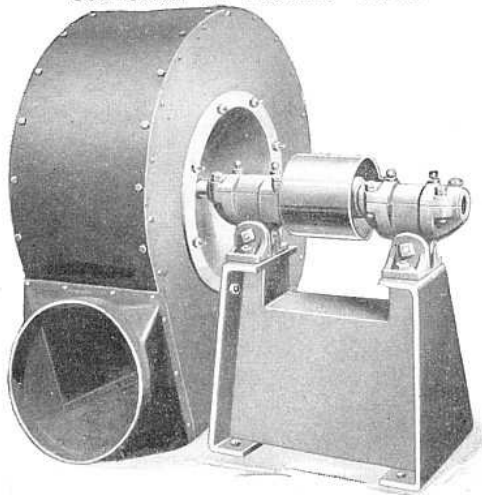

Buffalo Standard Reversible Single Mill Exhauster, Bottom Horizontal Discharge

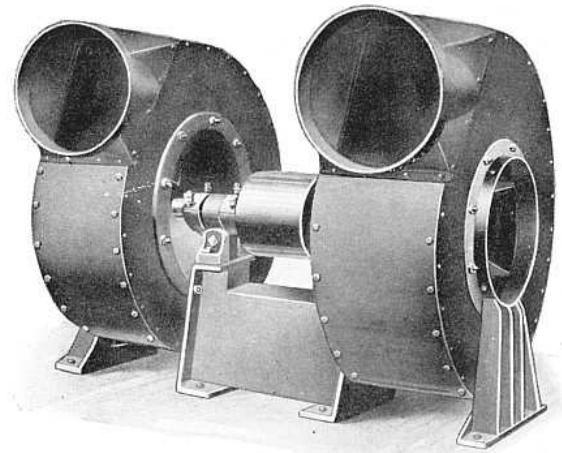

Buffalo Standard Reversible Double Mill Exhauster—Top Horizontal Discharge

BUFFALO STANDARD MILL EXHAUSTERS

Capacities Under Normal Working Conditions

Size	1" Static Pressure or 0.577 Ounces			2" Static Pressure or 1.154 Ounces			3" Static Pressure or 1.734 Ounces			4" Static Pressure or 2.307 Ounces			5" Static Pressure or 2.884 Ounces		
	R.P.M.	A.P.M.	H.P.	R.P.M.	A.P.M.	H.P.	R.P.M.	A.P.M.	H.P.	R.P.M.	A.P.M.	H.P.	R.P.M.	A.P.M.	H.P.
25	898	890	.25	1270	1260	.70	1555	1540	1.29	1795	1780	1.98	2008	1990	2.78
30	747	1280	.36	1058	1815	1.01	1294	2220	1.85	1495	2565	2.85	1672	2870	3.98
35	640	1740	.48	905	2465	1.37	1109	3020	2.52	1280	3485	3.88	1430	3900	5.42
40	561	2275	.64	793	3220	1.79	972	3940	3.30	1122	4550	5.09	1255	5090	7.12
45	499	2880	.80	706	4070	2.27	865	4990	4.17	998	5760	6.44	1117	6450	8.98
50	449	3555	.99	635	5030	2.80	778	6160	5.15	898	7120	7.95	1004	7960	11.1
55	408	4300	1.20	578	6100	3.39	707	7460	6.23	816	8620	9.62	913	9635	13.4
60	374	5120	1.43	529	7250	4.04	648	8870	7.42	748	10250	11.4	836	11450	16.0
70	321	6975	1.94	453	9865	5.50	555	12070	10.1	640	13930	15.6	715	15580	21.7
80	281	9100	2.54	397	12880	7.79	486	15760	13.2	561	18200	20.4	628	20360	28.5
90	249	11520	3.21	353	16280	9.09	432	19960	16.7	499	23040	25.8	558	25800	36.0
100	225	14220	3.96	318	20120	11.2	389	24640	20.6	449	28480	31.8	502	31840	44.3
Size	6" Static Pressure or 3.460 Ounces			7" Static Pressure or 4.04 Ounces			8" Static Pressure or 4.614 Ounces			9" Static Pressure or 5.19 Ounces			10" Static Pressure or 5.768 Ounces		
	R.P.M.	A.P.M.	H.P.	R.P.M.	A.P.M.	H.P.	R.P.M.	A.P.M.	H.P.	R.P.M.	A.P.M.	H.P.	R.P.M.	A.P.M.	H.P.
25	2200	2180	3.66	2375	2355	4.61	2540	2515	5.62	2692	2670	6.70	2840	2815	7.86
30	1830	3140	5.23	1978	3390	6.60	2115	3630	8.06	2240	3850	9.62	2365	4055	11.2
35	1568	4270	7.12	1693	4615	8.97	1810	4930	10.9	1920	5230	13.1	2026	5515	15.3
40	1373	5575	9.33	1483	6025	11.8	1587	6440	14.4	1683	6830	17.2	1773	7200	20.07
45	1223	7060	11.8	1322	7625	14.9	1413	8150	18.1	1498	8650	21.7	1578	9120	25.36
50	1100	8720	14.6	1188	9420	18.4	1270	10070	22.4	1347	10680	26.7	1420	11250	31.3
55	1000	10550	17.6	1080	11400	22.2	1154	12180	27.1	1224	12930	32.4	1290	13620	37.87
60	915	12550	20.9	989	13560	26.4	1058	14500	32.3	1120	15370	38.5	1183	16200	45.1
70	789	17070	28.5	847	18430	35.8	905	19700	43.6	960	20900	52.5	1013	22050	61.2
80	687	22300	37.3	742	24100	47.2	794	25760	57.5	842	27320	68.7	887	28800	80.3
90	611	28240	47.2	661	30500	59.5	706	32600	72.7	749	34600	86.8	789	36480	101.5
100	550	34880	58.2	595	37680	73.3	636	40280	89.6	674	42720	107.0	710	45000	125.2

Buffalo

Buffalo Standard Reversible Mill Exhausters (SINGLE)

**Clockwise
Bottom Horizontal
Discharge**

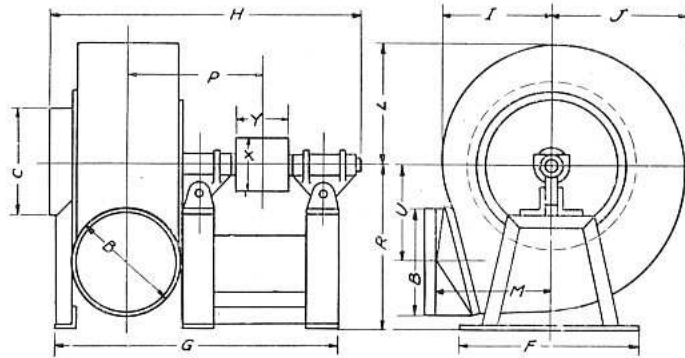

Dimensions in Inches

Size	B	C	F	G	H	I	J	L	M	P	R	U	X	Y
25	10	10	11 1/2	26 3/4	28 3/4	9 7/8	12 3/8	11 1/8	10 5/8	13 1/16	15 1/4	9 1/8	5	4
30	12	12	13	29 3/8	32 1/4	12	15	13 1/2	13	14 1/16	18	11	6	4 1/2
35	14	14	14	32 3/8	35	13 3/8	17 3/8	15 5/8	15 1/8	15 1/16	20 3/4	13 1/8	7	5 1/2
40	16	16	15	35 7/8	38 3/4	16	20	18	16 7/8	17 1/16	24	15 1/16	8	6 1/2
45	18	18	16 1/2	40 3/4	43 3/4	17 7/8	22 3/8	20 1/8	19 1/4	19 1/16	26 5/8	16 1/2	9	7 1/2
50	20	20	18	44	47	19 3/4	24 3/4	22 1/4	21 1/4	21 1/16	29 1/4	18 1/8	10	8 1/2
55	22	22	26	48	51	21 5/8	27 1/8	24 3/8	23	23 1/8	32	19 1/16	11	9 1/2
60	24	24	27	50 1/2	53 1/2	23 3/4	29 3/4	26 3/4	25	24 3/8	35	22 1/16	12	10 1/2
70	28	28	31	56 3/4	60 1/2	27 1/2	34 1/2	31	28 3/4	27 1/4	40	25 1/16	14	11 1/2
80	32	32	33	61	64 3/4	31 1/2	39 1/2	35 1/2	28 5/8	29 5/8	45 1/2	29 1/2	16	12 1/2

(DOUBLE)

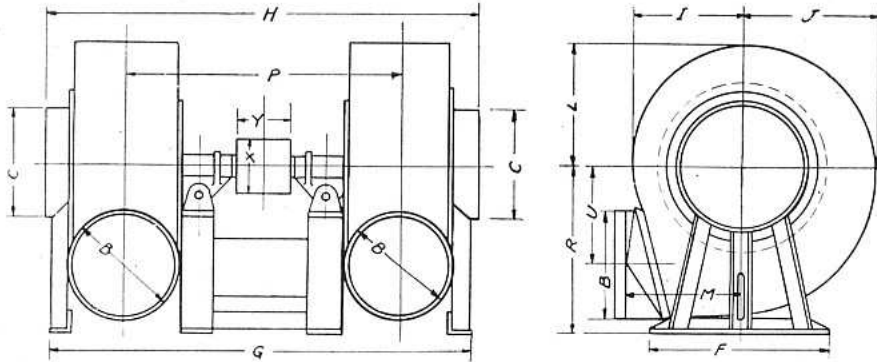

**Clockwise
Bottom
Horizontal
Discharge**

Dimensions in Inches

Size	B	C	F	G	H	I	J	L	M	P	R	U	X	Y
30	12	12	13	45 5/8	46	12	15	13 1/2	13	30 3/4	18	11	6	6 1/2
35	14	14	14	50 3/4	51 1/8	13 7/8	17 3/8	15 5/8	15 1/8	34 3/4	20 3/4	13 1/8	7	7 1/2
40	16	16	15	56 1/4	56 3/8	16	20	18	16 7/8	38 1/8	24	15 1/16	8	8 1/2
45	18	18	16 1/2	64 1/2	64 1/8	17 7/8	22 3/8	20 1/8	19 1/4	42 7/8	26 5/8	16 1/2	10	9 1/2
50	20	20	18	70 3/8	69 7/8	19 3/4	24 3/4	22 1/4	21 1/4	46 5/8	29 1/4	18 1/8	12	10 1/2
55	22	22	26	75 1/2	75	21 5/8	27 1/8	24 3/8	23	50 1/8	32	19 1/16	13	11 1/2
60	24	24	27	81 5/8	81 1/8	23 3/4	29 3/4	26 3/4	25	54 3/4	35	22 1/16	14	12 1/2
70	28	28	31	90 7/8	90 5/8	27 1/2	34 1/2	31	28 3/4	59 1/4	40	25 1/16	16	14
80	32	32	33	101 1/8	100 7/8	31 1/2	39 1/2	35 1/2	28 5/8	66 1/2	45 1/2	29 1/2	20	16



Buffalo Slow Speed, High Efficiency Mill Exhausters

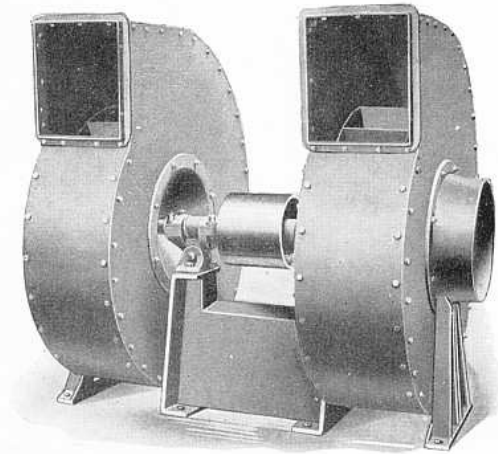

Double Slow Speed Mill Exhauster

It has long been recognized by fan builders, or at least by those who do any experimental work, that the ordinary proportions of mill exhausters are such as to give large capacity but not very high efficiency. We believe, and our results show, that we have gone into this question more thoroughly than any other manufacturer, and that the Buffalo slow speed fan design is the best on the market.

Actual installation of Buffalo Slow Speed Exhausters show power savings from 15 to 50%. The former figure represents the difference in efficiency between this fan and the standard fans, and in the latter is included the additional saving due to improved layout of piping often effected by our engineering service.

In all Buffalo Slow Speed Exhausters the material does not come in contact with the back side sheet of the fan housing, which greatly increases the life of the fan.

When refuse from the barkers or similar material is to be handled, a still heavier construction is essential. The proper apparatus will always be furnished upon receipt of full details about requirements.

It is evident enough that all of the claims made for high efficiency mill exhausters cannot be true. Outside of the actual experience, nothing would be so apt to convince a customer as a truthful explanation of our claims for high efficiency.

Slow speed fans are no more efficient on account of the reduced speed, except in so far as they cause less slippage of belts. They do decrease the wear and tear and vibration, and in the long run would be a good investment even if the power required were the same.

Manufacturers who actually build a slow speed fan do not use a special wheel inside the regular housing, but use an entirely different design, and besides the reduction in speed, they make some attempt to secure better efficiency by improvements in design.

This illustrates the difference in size and design of Buffalo Standard and Slow Speed Exhausters. Having the same capacities both are called 50" fans.

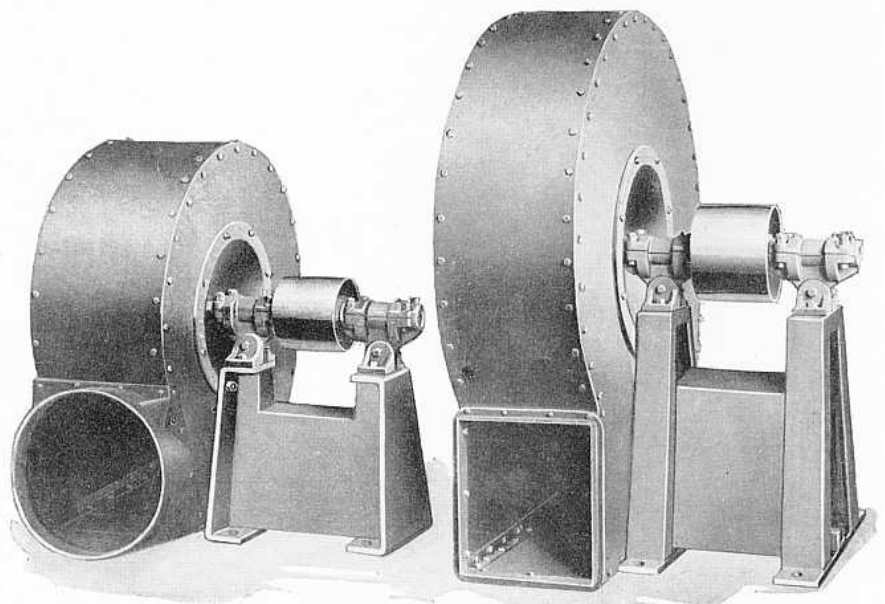

Standard Mill Exhauster

Slow Speed, High Efficiency
Mill Exhauster

Buffalo

Buffalo High Efficiency Direct Connected Exhausters

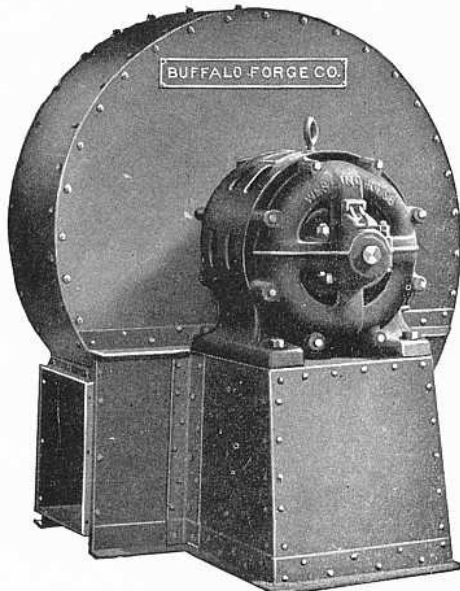

Buffalo Slow Speed Mill Exhauster
Direct Connected to Motor

Electric driven direct-connected slow speed exhausters are highly recommended. Belting is avoided, floor space economized, and wear and tear reduced to a minimum.

The first cost of such a unit is more than for an ordinary fan, but due to the lower maintenance cost, it is invariably an investment which from our experience pays for itself in two years.

In requesting quotations, give characteristics of electric current.

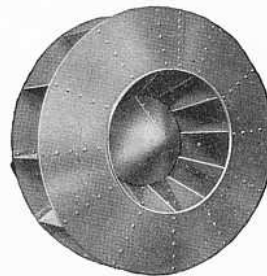

Buffalo Slow Speed High Efficiency Blast Wheel

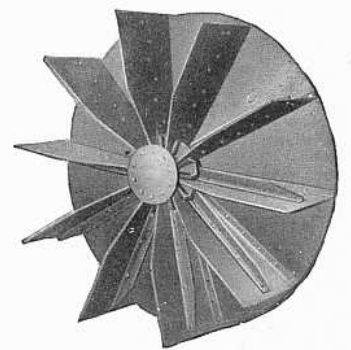

Blast Wheel for stringy material

Buffalo Slow Speed Mill Exhausters

CAPACITIES UNDER NORMAL WORKING CONDITIONS

Size	1" Static Pressure or 0.577 Ounces			2" Static Pressure or 1.154 Ounces			3" Static Pressure or 1.734 Ounces			4" Static Pressure or 2.307 Ounces			5" Static Pressure or 2.884 Ounces		
	R.P.M.	A.P.M.	H.P.	R.P.M.	A.P.M.	H.P.	R.P.M.	A.P.M.	H.P.	R.P.M.	A.P.M.	H.P.	R.P.M.	A.P.M.	H.P.
25	591	890	.19	837	1260	.55	1024	1540	1.01	1182	1780	1.55	1322	1990	2.17
30	494	1280	.28	698	1815	.79	855	2220	1.45	988	2565	2.24	1104	2870	3.13
35	423	1740	.38	598	2465	1.07	733	3020	1.97	846	3485	3.03	947	3900	4.25
40	370	2275	.50	523	3220	1.40	641	3940	2.58	740	4550	3.98	827	5090	5.56
45	329	2880	.62	466	4070	1.78	570	4990	3.26	658	5760	5.00	737	6450	7.03
50	296	3555	.77	419	5030	2.20	513	6160	4.03	592	7120	6.20	662	7960	8.68
55	269	4300	.94	381	6100	2.67	466	7460	4.88	538	8620	7.50	602	9635	10.5
60	247	5120	1.12	349	7250	3.17	427	8870	5.80	493	10250	8.93	551	11450	12.4
70	211	6975	1.51	299	9865	4.30	366	12070	7.88	422	13930	12.1	473	15580	17.1
80	185	9100	2.00	261	12880	5.58	320	15760	10.3	370	18200	15.9	413	20360	22.2
90	164	11520	2.49	233	16280	7.17	285	19960	13.1	329	23040	20.2	368	25800	28.2
100	148	14220	3.11	209	20120	8.78	256	24640	16.1	296	28480	24.9	330	31840	34.5
Size	6" Static Pressure or 3.460 Ounces			7" Static Pressure or 4.04 Ounces			8" Static Pressure or 4.614 Ounces			9" Static Pressure or 5.19 Ounces			10" Static Pressure or 5.768 Ounces		
	R.P.M.	A.P.M.	H.P.	R.P.M.	A.P.M.	H.P.	R.P.M.	A.P.M.	H.P.	R.P.M.	A.P.M.	H.P.	R.P.M.	A.P.M.	H.P.
25	1448	2180	2.86	1563	2355	3.59	1672	2515	4.39	1772	2670	5.22	1868	2815	6.13
30	1209	3140	4.11	1307	3390	5.19	1397	3630	6.33	1480	3850	7.55	1562	4055	8.88
35	1038	4270	5.59	1120	4615	7.03	1197	4930	8.55	1270	5230	10.3	1338	5515	12.0
40	906	5575	7.30	978	6025	9.20	1046	6440	11.2	1110	6830	13.4	1170	7200	15.8
45	806	7060	9.20	871	7625	11.6	931	8150	14.2	987	8650	16.9	1041	9120	19.8
50	725	8720	11.4	783	9420	14.4	837	10070	17.6	888	10680	21.0	935	11250	24.4
55	660	10550	13.9	712	11400	17.4	762	12180	21.3	807	12930	25.4	851	13620	29.7
60	604	12550	16.4	652	13560	20.7	696	14500	25.2	739	15370	30.2	779	16200	35.3
70	517	17070	22.3	559	18430	28.2	597	19700	34.3	633	20900	40.8	669	22050	48.0
80	453	22300	29.2	489	24100	36.8	523	25760	44.8	555	27320	53.6	585	28800	63.2
90	403	28240	36.8	435	30500	46.6	465	32600	56.8	493	34600	67.8	520	36480	79.6
100	362	34880	45.7	391	37680	57.3	418	40280	70.0	443	42720	83.3	467	45000	97.8

Buffalo

Buffalo Slow Speed High Efficiency Mill Exhausters (SINGLE)

**Clockwise
Bottom Horizontal
Discharge**

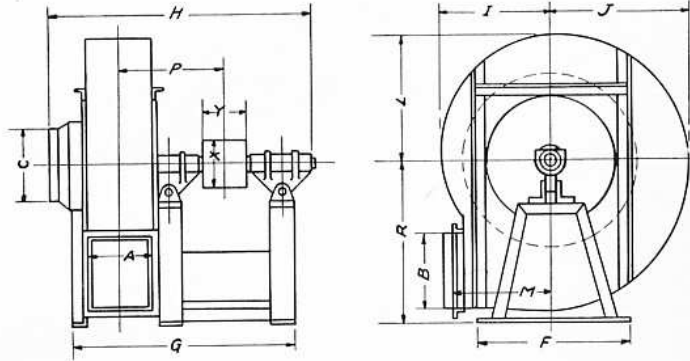

Dimensions in Inches

Size	A	B	C	F	G	H	I	J	L	M	P	R	X	Y
25	8 ⁵ / ₈	9 ⁷ / ₈	10 ¹ / ₂	13	28 ¹ / ₄	32 ³ / ₈	13 ¹¹ / ₁₆	17 ¹¹ / ₁₆	15 ³ / ₈	12 ¹ / ₄	13 ¹ / ₂	20 ³ / ₄	6	4 ¹ / ₂
30	10 ¹ / ₈	12	12 ¹ / ₂	14 ¹ / ₂	28 ⁵ / ₈	32 ³ / ₄	16 ³ / ₈	20 ⁷ / ₈	18 ³ / ₈	14 ⁷ / ₈	13 ⁵ / ₈	24 ³ / ₈	8	5
35	11 ³ / ₄	13 ⁷ / ₈	14 ⁵ / ₈	16	31 ⁵ / ₈	36	19 ¹ / ₄	23 ⁷ / ₈	21 ¹ / ₂	17 ⁵ / ₈	15 ¹¹ / ₁₆	28 ¹ / ₄	9	6
40	13 ³ / ₈	15 ⁷ / ₈	16 ⁵ / ₈	24 ³ / ₄	36 ¹ / ₄	40 ³ / ₈	21 ³ / ₄	27	24 ⁵ / ₈	20 ¹ / ₄	17 ⁵ / ₈	31 ⁵ / ₈	10	7
45	15	18	18 ⁵ / ₈	26 ¹ / ₂	39 ¹¹ / ₁₆	45	24 ¹ / ₂	30 ¹ / ₂	27 ¹ / ₂	23	19 ¹¹ / ₁₆	35 ¹ / ₂	11	8
50	17	19 ⁵ / ₈	20 ⁵ / ₈	28 ¹ / ₂	42 ¹¹ / ₁₆	48 ¹ / ₄	27 ³ / ₈	34 ¹ / ₈	30 ³ / ₄	25 ⁷ / ₈	20 ¹¹ / ₁₆	39 ¹ / ₂	12	9
55	18 ¹ / ₂	21 ³ / ₄	22 ³ / ₄	30 ¹ / ₂	46 ¹¹ / ₁₆	52 ¹ / ₂	30	37 ¹ / ₄	33 ³ / ₈	28 ¹ / ₄	22 ¹¹ / ₁₆	42 ⁷ / ₈	13	10
60	20 ¹ / ₄	23 ¹ / ₂	24 ³ / ₄	33	49 ¹¹ / ₁₆	56	32 ³ / ₄	40 ³ / ₄	36 ³ / ₄	31	23 ¹¹ / ₁₆	46 ³ / ₄	14	11
70	23 ³ / ₈	27 ³ / ₈	28 ³ / ₄	38 ¹ / ₂	54 ¹¹ / ₁₆	63 ¹ / ₄	38 ¹ / ₈	47 ³ / ₈	42 ¹ / ₄	36 ³ / ₈	26 ³ / ₈	54	16	12
80	26 ⁷ / ₈	31 ¹ / ₈	32 ³ / ₄	41 ³ / ₄	59 ¹¹ / ₁₆	68 ³ / ₈	43 ³ / ₈	54 ³ / ₈	49	41 ⁷ / ₈	28 ⁷ / ₈	61 ³ / ₄	20	14

(DOUBLE)

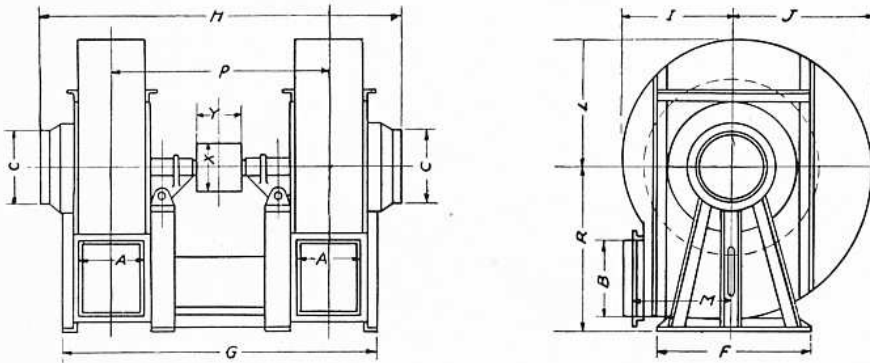

**Clockwise
Bottom
Horizontal
Discharge**

Dimensions in Inches

Size	A	B	C	F	G	H	I	J	L	M	P	R	X	Y
25	8 ⁵ / ₈	9 ⁷ / ₈	10 ¹ / ₂	13	42 ¹ / ₂	46	13 ¹¹ / ₁₆	17 ¹¹ / ₁₆	15 ³ / ₈	12 ¹ / ₄	30 ¹ / ₄	20 ³ / ₄	6	6 ¹ / ₂
30	10 ¹ / ₈	12	12 ¹ / ₂	14 ¹ / ₂	44	47 ¹ / ₂	16 ³ / ₈	20 ³ / ₈	18 ³ / ₈	14 ⁷ / ₈	30	24 ³ / ₈	8	7 ¹ / ₂
35	11 ³ / ₄	13 ⁷ / ₈	14 ⁵ / ₈	16	48 ¹ / ₂	52 ³ / ₈	19 ¹ / ₄	23 ⁷ / ₈	21 ¹ / ₂	17 ⁵ / ₈	32 ⁷ / ₈	28 ¹ / ₄	9	8 ¹ / ₂
40	13 ³ / ₈	15 ⁷ / ₈	16 ⁵ / ₈	24 ³ / ₄	56 ⁷ / ₈	59 ³ / ₄	21 ³ / ₄	27	24 ⁵ / ₈	20 ¹ / ₄	38 ¹ / ₄	31 ⁵ / ₈	11	9 ¹ / ₂
45	15	18	18 ⁵ / ₈	26 ¹ / ₂	62 ³ / ₈	66 ³ / ₈	24 ¹ / ₂	30 ¹ / ₂	27 ¹ / ₂	23	42 ³ / ₈	35 ¹ / ₂	12	10 ¹ / ₂
50	17	19 ⁵ / ₈	20 ⁵ / ₈	28 ¹ / ₂	68 ¹ / ₈	72 ¹ / ₈	27 ³ / ₈	34 ¹ / ₈	30 ³ / ₄	25 ⁷ / ₈	45 ⁵ / ₈	39 ¹ / ₂	13	11 ¹ / ₂
55	18 ¹ / ₂	21 ³ / ₄	22 ³ / ₄	30 ¹ / ₂	74 ¹ / ₈	79 ¹ / ₈	30	37 ¹ / ₄	33 ³ / ₈	28 ¹ / ₄	50 ¹ / ₈	42 ⁷ / ₈	14	12 ¹ / ₂
60	20 ¹ / ₄	23 ¹ / ₂	24 ³ / ₄	33	81 ¹ / ₈	85 ⁷ / ₈	32 ³ / ₄	40 ³ / ₄	36 ³ / ₄	31	54 ⁵ / ₈	46 ³ / ₄	16	15
70	23 ³ / ₈	27 ³ / ₈	28 ³ / ₄	38 ¹ / ₂	91 ⁷ / ₈	98 ¹ / ₂	38 ¹ / ₈	47 ³ / ₈	42 ¹ / ₄	36 ³ / ₈	62 ¹ / ₄	54	20	18
80	26 ⁷ / ₈	31 ¹ / ₈	32 ³ / ₄	41 ³ / ₄	103 ³ / ₈	111 ³ / ₈	43 ³ / ₈	54 ³ / ₈	49	41 ⁷ / ₈	70 ¹ / ₂	61 ³ / ₄	24	22



Buffalo Dust and Refuse Collectors



These collectors or separators are built of heavy galvanized sheet steel, securely riveted and stiffened to meet the strains of service.

In operation, the air and refuse matter, discharged through the inlet near the top of the collector, is thrown against the side with a whirling motion. The air, thus suddenly admitted into an enlarged area, loses most of its velocity and escapes through the opening in the top. The heavier refuse matter, no longer supported by the velocity of the air, falls through the discharge orifice into the bin or other receptacle provided for it.

The "Buffalo" has no equal for separating such materials as shavings, sawdust, refuse from tumbling barrels, emery wheels, sanders, etc.

For handling abrasive materials such as emery dust and fine coal, an extra heavily constructed collector is recommended.

The "Buffalo Collector" imposes but slight back pressure on the fan. It will be less than the equivalent of the velocity in the pipe.

Diameter of Inlet, Inches	Size of Refuse Outlet, Inches	Diameter of Shell, Inches	Overall Length of Collector, Inches
6	6	24	40
8	7	32	52
10	8	40	64
12	8	48	76
14	8	56	89
16	8	64	101
18	9	72	114
20	10	80	126
22	11	88	139
24	12	96	151
26	13	104	163
28	14	112	175
30	15	120	187
32	16	128	200
34	17	136	212
36	18	144	224

Buffalo Slide-Pattern Blast Gates

Blast gates are necessary in every branch outlet of a blow-pipe system. They save handling useless air, thereby reducing the power consumption and increasing the efficiency of the system, since the suction is increased in the remaining branch pipes when those not in use are shut off. The blast gates should be of adequate size.

The frames of these gates are of heavy cast iron. The slides are of steel plate.

Size	Inside Diameter Inches	Axial Length Inches	Weight Pounds
2	1 $\frac{3}{4}$	3	1 $\frac{1}{2}$
2 $\frac{1}{2}$	2 $\frac{1}{4}$	3 $\frac{1}{2}$	2
3	2 $\frac{3}{4}$	4	2 $\frac{1}{2}$
4	3 $\frac{1}{4}$	5 $\frac{1}{4}$	6
5	4 $\frac{3}{4}$	5 $\frac{3}{4}$	7
6	5 $\frac{1}{4}$	7	11
7	6 $\frac{3}{4}$	7 $\frac{1}{2}$	16
8	7 $\frac{1}{4}$	8 $\frac{1}{4}$	25
10	9 $\frac{3}{8}$	9	31
12	11 $\frac{1}{2}$	9	36
14	13 $\frac{1}{2}$	8 $\frac{1}{4}$	45
16	15 $\frac{1}{4}$	9 $\frac{3}{4}$	75
18	17 $\frac{1}{2}$	9 $\frac{1}{4}$	80
20	19 $\frac{1}{4}$	8 $\frac{1}{4}$	95
24	23 $\frac{1}{2}$	9 $\frac{3}{4}$	120
26	25 $\frac{1}{2}$		150
30	29 $\frac{1}{2}$		205
36	35 $\frac{1}{2}$		280
42	41 $\frac{1}{2}$		350
48	47 $\frac{1}{2}$		460

} Built up of angle
} Irons and steel plate.

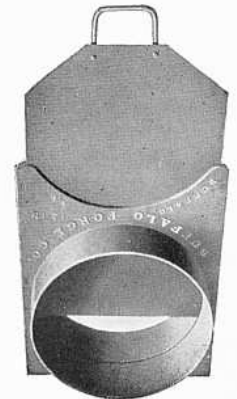

NOTE:—The sizes given are the outside diameter of collar of gates over which the pipe fits.

Buffalo

Buffalo Baby Conoidal Fans

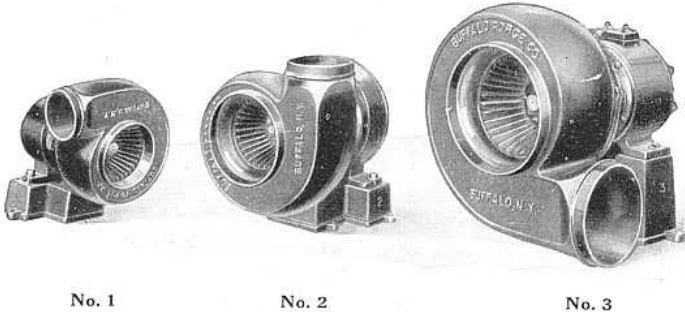

The Baby Conoidal fan is of the high efficiency multiblade type with blast wheel of the same design as the Niagara Conoidal (Type N) which has met with such marked success. Housing is cast iron and can be swung around to discharge in any desired direction. This fan furnishes a large volume of air at a relatively low pressure with moderate speed. The wheel is accurately balanced, assuring a smooth-running, noiseless machine.

It is unexcelled for all kinds of drying and cooling purposes, for supplying fresh, cool air to offices, homes, staterooms, telephone booths, etc., and for exhausting smoke fumes and foul air from kitchens, restaurants, lavatories, etc.

Cord and plug are furnished; no expense for installing, simply attach to an electric light socket. Outfits are furnished with 110 or 220 Volt D. C. motors and 110 or 220 Volt single phase, 60 cycle, A. C. Motors. Larger sizes.

Number of Fan	Revolutions per Minute	Air per Minute Cubic Feet	PRESSURE			
			Static Inches Water	Horse Power	Horse Power Motor	Shipping Weight Lbs.
1	1740	75	0.17	0.012	1/30	40
2	1740	160	0.25	0.030	1/15	55
3	1140	260	0.24	0.160	1/5	110
	1740	500	0.47	0.180	1/4	115

Buffalo Experimental Exhausters

These small cast iron exhausters of the pulley type (which may also be used as blowers) correspond with reference to capacity, very closely to the first three sizes of the steel pressure blowers, but are of somewhat lighter construction. They differ from our other fans in having shells split vertically and plain babitted bearings. They are intended especially for blowing small fires for horseshoer's work, for experimental purposes where a small quantity of air is required, and also where a blower or exhauster is required temporarily. As exhausters they are used for serving small emery and polishing wheels. The No. 0 is sufficient for serving one small fire, the No. 1/2 for two or three light fires for horseshoeing and similar work.



No. 00 Experimental Exhauster

No.	Outside Diam. of Outlet	Height Inches	Weight Pounds	Pulley Diameter and Face Inches
00	2 3/4	11	20	1 1/4 x 1 1/4
0	3	15	30	1 5/8 x 1 5/8
1/2	4 1/2	20	45	1 3/4 x 2

"Buffalo"

Buffalo Pulley Breezo and Pulley Disk Fans

Pulley Breezo Propeller Fan

Where a large volume of air is to be handled against little or no resistance, the Buffalo Pulley Breezo will be found ideal.

This fan has the multiblade wheel, the same as used on the electric "Breezo" described on the next page, but is arranged for pulley drive as shown. The curved blades handle an exceptionally large amount of air.

Heavy duty, dust-proof ball bearings with deep raceway in both inner and outer rings, insure efficient, trouble-free operation.

Pulley Breezos are made in five sizes from 16" to 36". Prices are exceptionally low for fans of this quality.

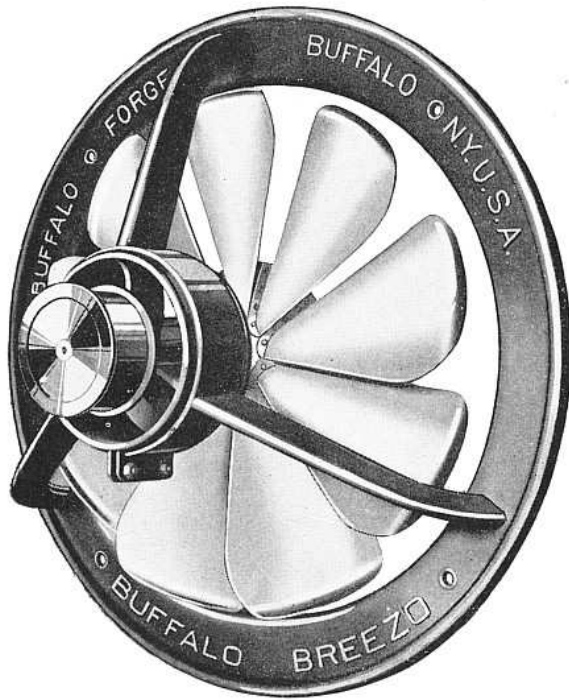

Specifications

Size	Normal Speed	Cu. Ft. Air per Min.	H.P.	Pulley	Wgt. Lbs.
16 in.	1150	1500	.09	5 x 2 1/4 in.	38
18 in.	1150	2400	.12	5 x 2 1/4 in.	45
24 in.	850	4000	.21	5 x 2 1/4 in.	60
30 in.	670	6200	.34	7 x 3 1/4 in.	110
36 in.	525	8500	.44	7 x 3 1/4 in.	130

Type "K" Disk Fans

The Type "K" Disk Fan is made with straight steel blades, tilted at just the right angle to draw air continuously through the wheel without noise or loss in efficiency.

Heavy, well-riveted blades with sturdy angle iron frame and large bearings, make these fans rigid and suitable for high speed without vibration.

We make Type "K" fans in sizes from 42" to 12' in diameter and are able to make quick delivery on all sizes.

Specifications

Size	Normal Speed	Cu.Ft. Air Per Min.	H.P.	Pulley	Wgt. Lbs.
42 in.	450	11,200	.50	12 x 3 1/2 in.	250
48 in.	400	15,000	.70	14 x 3 1/2 in.	310
54 in.	350	18,400	.85	16 x 4 1/2 in.	470
60 in.	320	23,400	1.10	18 x 4 1/2 in.	530
72 in.	265	33,500	1.55	20 x 5 1/2 in.	850
84 in.	225	45,000	2.10	24 x 5 1/2 in.	1500

Larger Sizes on Application.

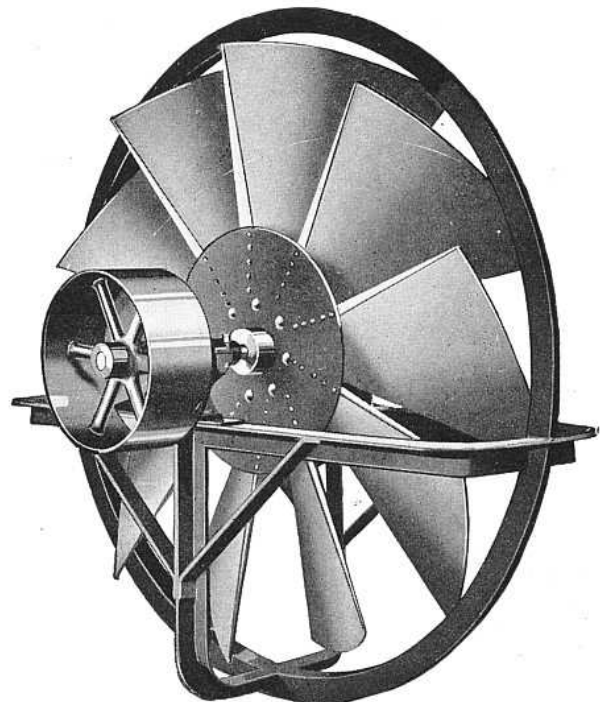

"Buffalo"

Buffalo Breezo Electric Ventilating Fans

The wide variety of its applications makes this fan a popular seller.

In stores, clubs, smoking rooms, creameries, dining rooms, kitchens, theatres, garages, laboratories, billiard parlors, cleaning and pressing shops, printing and typesetting plants, bakeries, laundries, washrooms and toilets and in many other places the Buffalo Breezo is used to remove smoke, odors, steam, fumes or stale air.

10 POINTS OF SUPERIORITY

- 20% MORE CAPACITY than other fans of the same diameter, speed and power consumption.
- STREAM LINE design and construction of the pressed steel ring permits the air to enter the wheel without frictional loss or eddy currents.
- BEARINGS are of extra large dimensions, bronze bushed (the shafts are nickel steel) while the wheel is placed close to the motor bearing, giving maximum overhang with resulting increased life of the bearing.
- LUBRICATION of bearings is such that each Fan will run 2500 hours without re-oiling.
- BAND and RING are locked and spot-welded to the arms which are very strong and of graceful design.
- HUBS are of machined steel locked securely to the wheel.
- NO BOLTS are used in the assembly of the ring and arms, nothing to work loose.
- PRESSED cold-rolled steel plate construction, die formed to accurate dimensions, perfect uniformity and balance.
- WEIGHT far less than other fans made of cast iron, even lighter than aluminum and far stronger.
- MOTOR is of totally enclosed type to keep out dirt and water. Large enough to carry the load continuously without depending on any artificial ventilation.

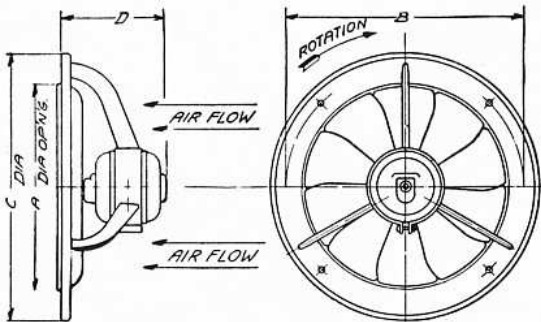

Size	A	B	C	D
12	12 1/2	14 1/4	15 1/2	6 1/2
18	18 3/4	21 1/2	24	9 1/4
24	25	28 1/2	32	14 1/4
30	31	35 1/2	40	18 3/4
36	37	42	47	18 7/8

Specifications

Size	Speed R.P.M.	Cap. Cu Ft.	Motor Size	Weight	
				Net	Shipping
12 in.	750	600	1/70 h.p.	18 lbs.	25 lbs.
12 in.	1150	1000	1/50 h.p.	18 lbs.	25 lbs.
16 in.	850	1100	1/20 h.p.	36 lbs.	50 lbs.
16 in.	1150	1500	1/10 h.p.	36 lbs.	50 lbs.
18 in.	850	1800	1/10 h.p.	44 lbs.	60 lbs.

1150 R.P.M. Motor on 12" is not reversible.

For direct current 110 and 220 volts, also 60 cycle and 25 cycle alternating current, either single or poly phase with the exception of 36" which can be furnished for 110 and 220 volts direct current and for 220 or 440 volt, 25 or 60 cycle 3 phase alternating current.

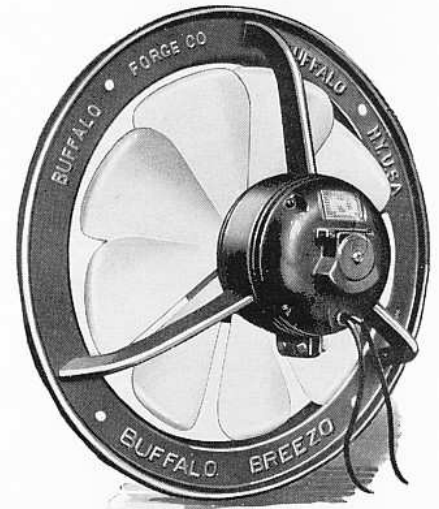

Specifications

Size	Speed R.P.M.	Cap. Cu Ft.	Motor Size	Weight	
				Net	Shipping
18 in.	1150	2400	1/6 h.p.	44 lbs.	60 lbs.
24 in.	670	3200	1/4 h.p.	85 lbs.	115 lbs.
24 in.	850	4000	1/3 h.p.	85 lbs.	115 lbs.
30 in.	670	6200	1/2 h.p.	165 lbs.	220 lbs.
36 in.	575	10000	3/4 h.p.	220 lbs.	275 lbs.

1150 R.P.M. Motor on 12" is not reversible.

Disk or Propeller Fans are unlike the centrifugal fan with reference to general performance. They are not generally used for handling air through long runs of piping, or against any appreciable resistance. For exhausting from a room, or handling a large volume of air against little resistance, they are more efficient than a centrifugal fan used for the same purpose.

For use in connection with BUFFALO "BREEZO" Fans we can furnish automatic louver dampers, which are illustrated in a folder sent on request. These automatically open up when the fan is started, and close tightly when the fan is stopped.

Index

	Page		Page
Buffalo Portable Forges			
Description of Blowers	4	No. 61-R Ball Bearing Drill	36
No. 200 Silent Blower	4, 15	No. 65-R Ball Bearing Drill	36
No. 500 Handy Geared Blower	4, 15	Buffalo Hand Power Punches, Shears, Bar Cutters and Benders	
No. 700 Climax Geared Blower	4, 15	Open Throat Combination Angle and Tee	
Variable Speed Electric Blowers	4, 15	Cutters	38
Constant Speed Electric Blowers	4, 15	No. 2 Angle and Tee Benders	38
Designation of Hoods	5	No. 22-SP "Armor Plate" Combination,	
No. 10 Series Forges	6	Punch, Shear and Bar Cutters	39
No. 12 Series Forges	7	No. 14 Bench Type Slitting Shears	39
No. 35 Series Forges	8	No. 19-A Bench Type Slitting Shears	39
No. 36 Series Forges	9	No. 20 "Armor Plate" Slitting Shears	40
No. 43 Series Forges	10	No. 20-C "Armor Plate" Slitting Shears	40
No. 48 Series Forges	11	No. 22 "Armor Plate" Slitting Shears	40
No. 49 Series Forges	11	No. 23 "Armor Plate" Slitting Shears	40
Nos. 061-062 Bufco Series Forges	12	No. 2-B "Armor Plate" Combination Punch	
Bufco Bench Forges	12	and Shears	41
Compressed Air Forges	13	No. 103-B "Armor Plate" Combination	
Oil Burning Forges	14	Punch and Shears	41
Buffalo Tuyeres	16	No. 104-B "Armor Plate" Combination	
Vulcan Tuyeres	16	Punch and Shears	41
Climax Tuyeres	16	No. 13 "Armor Plate" Punches	41
R. R. Tuyeres	16	No. 14 "Armor Plate" Punches	41
E. E. Tuyeres	16	No. 115-B "Armor Plate" Punches	41
J. J. Tuyeres	16	No. 103 "Armor Plate" Shears	42
Buffalo Stationary Forges		No. 104 "Armor Plate" Shears	42
Telescopic and Stationery Hoods	17	No. 5 "Armor Plate" Punch, Shear and	
Semi-Portable Forges	18	Barcutters	42
Nos. 85 and 86 Stationary Forges	19	No. 10 "Armor Plate" Contractor's Bar	
Nos. 885 and 886 Stationary Forges	19	Cutters	43
No. 97 Stationary Forges	20	No. 11 "Armor Plate" Contractor's Bar	
No. 98 Stationary Forges	20	Cutters	43
Buffalo Drills		"Armor Plate" Coping Machines	43
POWER DRILLS		"Armor Plate" Universal Iron Workers	44
25" Back-Geared Upright Power Drills	22	Buffalo Bending Rolls	45
24" Back-Geared Upright Power Drills	23	Other Buffalo Metal Working Machines	46
21" Back-Geared Upright Power Drills	24	Buffalo Combination Woodworking Machines	
20" Back-Geared Upright Power Drills	25	No. 1 Combination Woodworker	48-51
16" Motor Driven Floor and Bench Drills	26	No. 2 Combination Woodworker	52-54
15" Upright Power Drills	27	Buffalo Blowers and Exhausters	
12" Hi-Speed Bench Drills	28, 29	Volume Fans	56-58
Motor Drive Arrangement for Power Drills	30	Steel Pressure Blowers	59-60
Tapping Attachment for Power Drills	30	Standard Reversible Mill Exhausters	61-63
10" Three Speed Bench Drills	31	Slow Speed, High Efficiency Mill	
10" Junior Bench Drills	32	Exhausters	64-66
POST DRILLS		Dust and Refuse Collectors	67
No. 124 Ball Bearing Drill	33	Slide-Pattern Blast Gates	67
No. 117 Capstan Lever Drill	33	Baby Conoidal Fans	68
No. 515 Ball Bearing Drill	34	Experimental Exhausters	68
No. 616 Ball Bearing Drill	34	Pulley "Breezo" Fans	69
No. 614-R Ball Bearing Drill	35	Type "K" Disk Fans	69
No. 612 Ball Bearing Drill	35	Motor Driven "Breezo" Fans	70
No. 611-R Ball Bearing Drill	36		

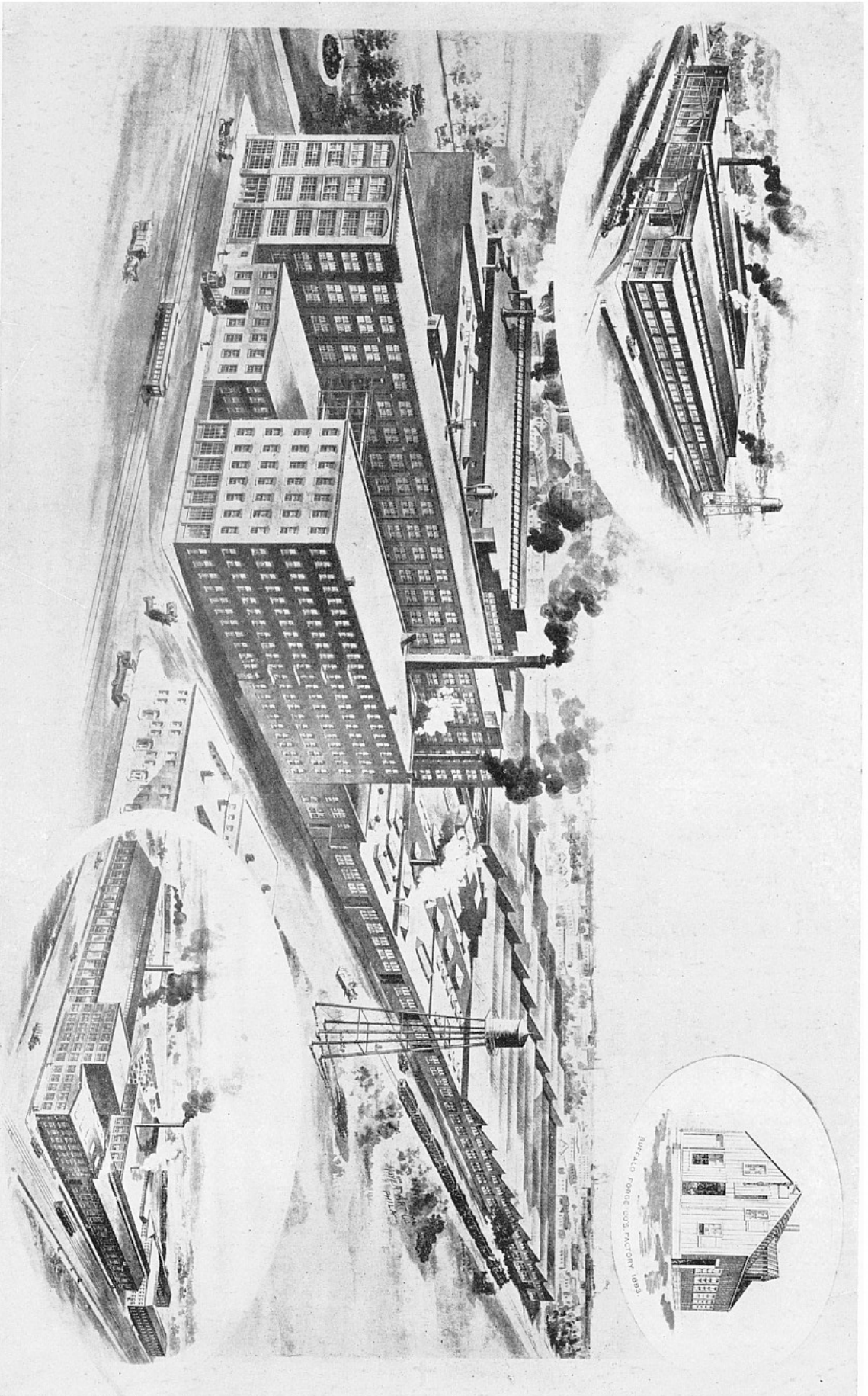

CANADIAN BLOWER & FORGE Co., Ltd.
Kitchener, Ont.

BUFFALO FORGE COMPANY
Buffalo, N. Y.

BUFFALO STEAM PUMP CO.
North Tonawanda, N. Y.

These three fine plants produce world-famed "Buffalo" products