

VOLUME 3 NO. 5



B.A.M.

The Blacksmiths' Association of Missouri is a chapter of The Artist-Blacksmiths' Association of North America. This organization is devoted to preservation, advancement, and communication between blacksmiths of Missouri and surrounding areas. BAM's newsletters goal is to support these ideas. Letters to the editor, tech tips, tools for sale, or any ideas which further these ends will be considered for publication.

BAM welcomes the use of any material printed in this newsletter provided the author and this organization be given credit.

OFFICERS

- | | |
|---|--|
| President
Bob Patrick
Box 205
Bethel, MO 63434
(816) 284-6687 | Vice-President
Don Asbee
Rt. 2 Hwy. 28
Bland, MO 65014
(314) 646-3657 |
| Secretary-Treasurer
Steve Austin
44 N.E. Munger Road
Claycomo, MO 64119
(816) 781-1512 | Editor
Doug Hendrickson
R.R. 1 Box 16 D
Lesterville, MO
63654
(314) 637-2576 |



A.A.M.

Chapter of Artist-Blacksmiths' Association of North America



**ABANA
Membership
Application**



ABA MEMBERSHIP APPLICATION

Date _____

Name: _____
Address: _____
City: _____
State: _____ Zip _____
Telephone: _____
New Member _____ Renewal _____

Have your own shop? Yes _____ No _____
Are you Full-time Smith _____
Part-time Smith _____
Interested _____

Suggestions for ABA: _____

Name: _____
Address: _____
City: _____ State _____ Zip _____
Phone: (_____) _____

- New Member Renewing Membership
 Practicing Smith Artist
 Teacher Amateur
 Student

How did you learn about ABANA? _____

- Fulltime Student \$15/yr
 Regular Member \$25/yr
 Family Membership (one vote) \$30/yr
 Senior Citizen \$20/yr
 Overseas Membership \$32/yr
 Contributory \$50/yr

Membership in ABANA includes a subscription to "The Anvil's Ring" and reduced fees at conferences

Send your check (U.S. funds only) along with the membership application to:

ABANA
P.O. Box 303
Cedarburg, WI 53012



1986 ABANA CONFERENCE

reprinted in part from the Newsletter of the Blacksmiths' Guild of the Potomac

The facilities at the Northern Arizona University were very compatible to our needs. The logistics were great, the conference center had a nice cafeteria where we ate and some lectures were held. Upstairs was a marvelous room looking out toward the San Francisco Peaks, where the exhibit was held. Outside, under trees were the areas set up for the demonstrations, all were under tarps to protect us from the monsoon rains we had each afternoon (so much for Arizona being dry!). The biggest adventure, however, was the dorm where we stayed. I'm not sure who (or what) designed it, but someone should check to be sure no blacksmiths are still roaming around lost. It had lots of corridors, and finding your room each time was definitely an interesting expedition. The travelling really did add to the fun!

The demonstrations were all excellent from everything I heard. There seemed to be someone demonstrating constantly from daylight well into the night. (Hope our "roving reporters" will share these with us.) There were also movies, slide shows and lectures going on all day and evening long. I attended a three-day seminar on pricing and marketing your ironwork, there was also another seminar on dealing with architects that others said was excellent. We'll have more information on these later, also.

Jim Batson of Birmingham, Alabama was elected President of ABANA for the next two years. It's a big job, but Jim should do a great job with it. We wish him, and the other new officers well during their terms.

Now is the time to start saving your pennies for the next ABANA Conference to be held in two years. It is scheduled to be held at the Sloss Furnaces in Birmingham, Alabama.

Another highlight of the conference was the first meeting ever held with the chapter newsletter editors. The meeting was suggested by Jim Ryan of the Upper Mid-West Blacksmiths' Association. It turned out to be much larger, and lasted much longer than he had even thought of. The enthusiasm shared by this group is fantastic! Hopefully we will be able to keep our members informed and enthused as well. Also present at this meeting was Robert Owings, new editor of the Anvil's Ring. He shared some of the problems the magazine is having, particularly getting new material, as so much is now published by the newsletters. The main request he had was for each of us to encourage our members to submit pictures and/or articles to the Anvil's Ring. They really need input from as many people as they can possibly get. He said not to worry if you do not think you write well enough, they will be glad to help you polish up any article you send them - just please send it!



These drawings for the hoodless-smokeless forge are reprinted from the Appalachian Blacksmiths Association September 86 newsletter, submitted by Bob Elliott.

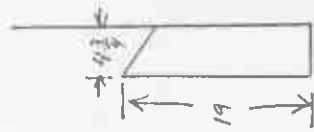
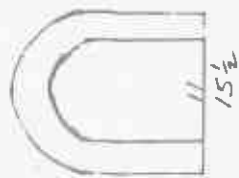
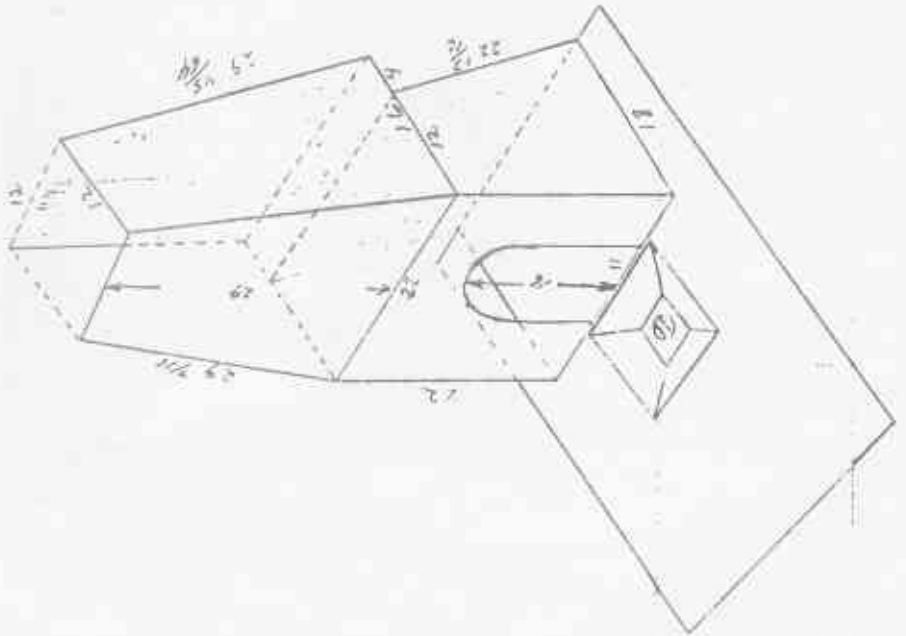

Smoke Deflector

TOP HPLF NEED 1 - FRONT
2 - SIDES
1 - BACK

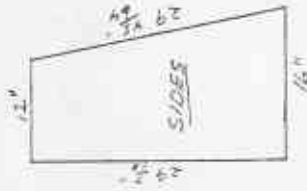
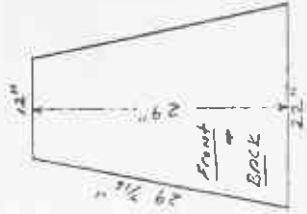

SMOKE SELF NEED 1



Bottom Half NEED 1 - Front
2 - SIDES
1 - BACK

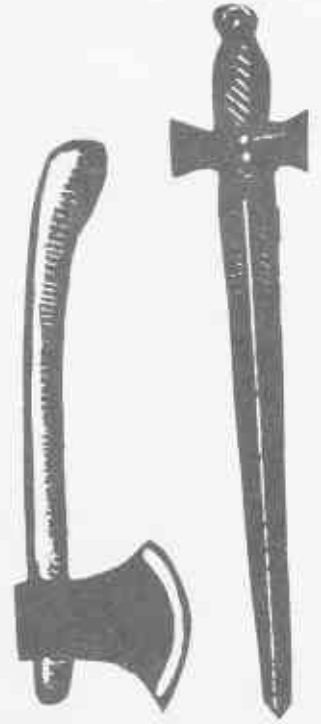
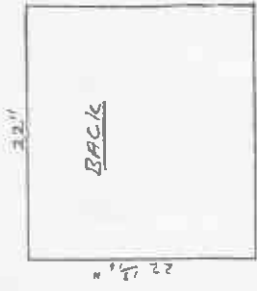
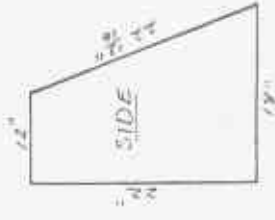
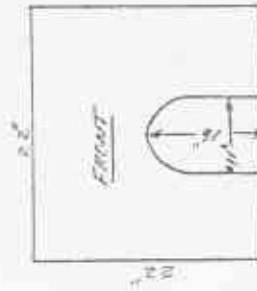

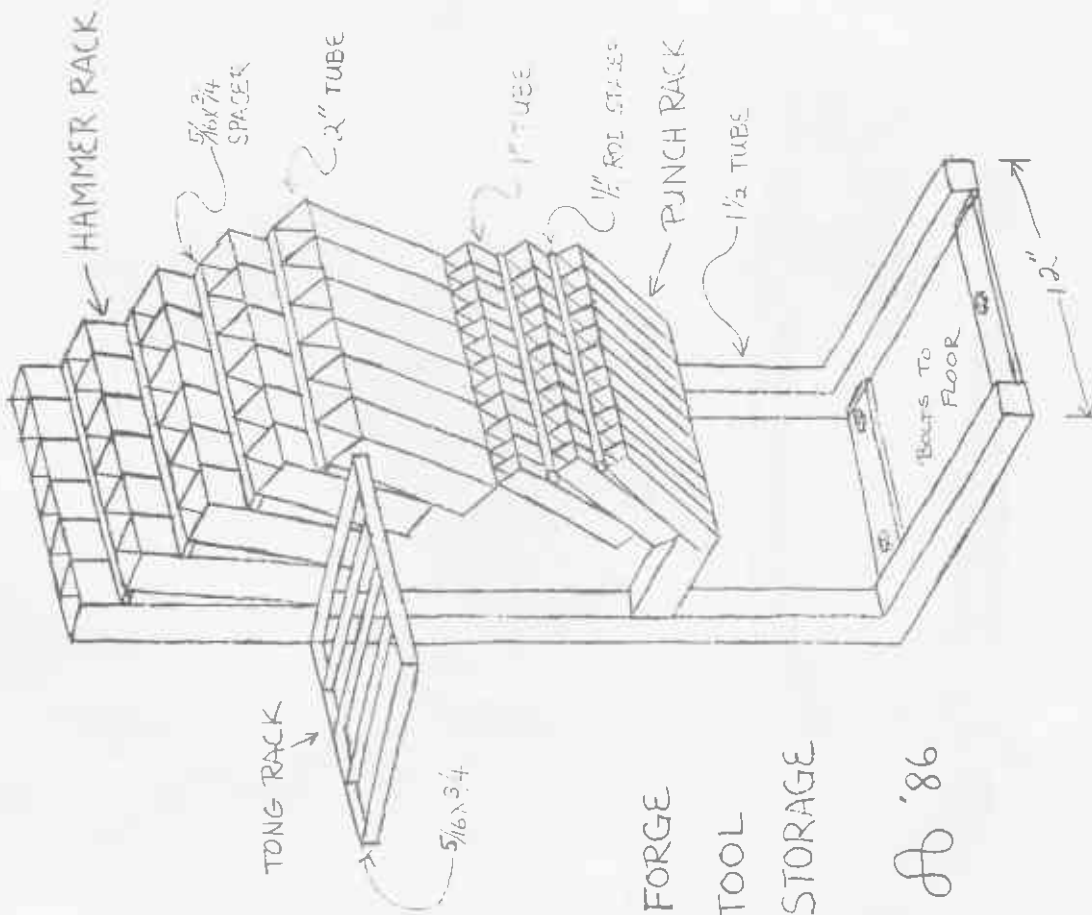

CULVER STOCKTON BAM EXHIBITION

NAME _____ ADDRESS _____

ENTRY NUMBER	FREESTANDING OR WALL MOUNT	TITLE OR DESCRIPTION	INSURANCE VALUE	SALE PRICE OR N.F.S IF NOT FOR SALE
1				
2				
3				
4				
5				

As soon as possible send this entry form to
 A1 Beck
 Culver Stockton College
 Canton, MO 63435

Also send Mr. Beck a list of people you wish to receive an exhibit brochure. Your work will be insured during the show. Label each piece with your name and entry number and deliver it to Don Asbee at Rt. 2 Hwy. 28 Bland, MO 65104 PH (314) 646-3657.

MR BECK MUST RECEIVE THIS FORM BEFORE DEC 12TH. YOUR WORK MUST BE TO ASBEE BEFORE JAN 5, 87

BAM

R.R. 1 Box 16 D

Lesterville, MO 63654

CHRISTMAS
22



BERNARD TAPPEL
RT. 1 BOX 81

HENLEY MO

65840

ADDRESS CORRECTION REQUESTED